



**NEUNDORFER  
PRECIPITATOR  
KNOWLEDGE**

# USER MANUAL

# MVC-IV

## **MICRO VOLTAGE CONTROL IV USER MANUAL**

© Neundorfer, Inc. 2005, 2009  
Revised: August 2009

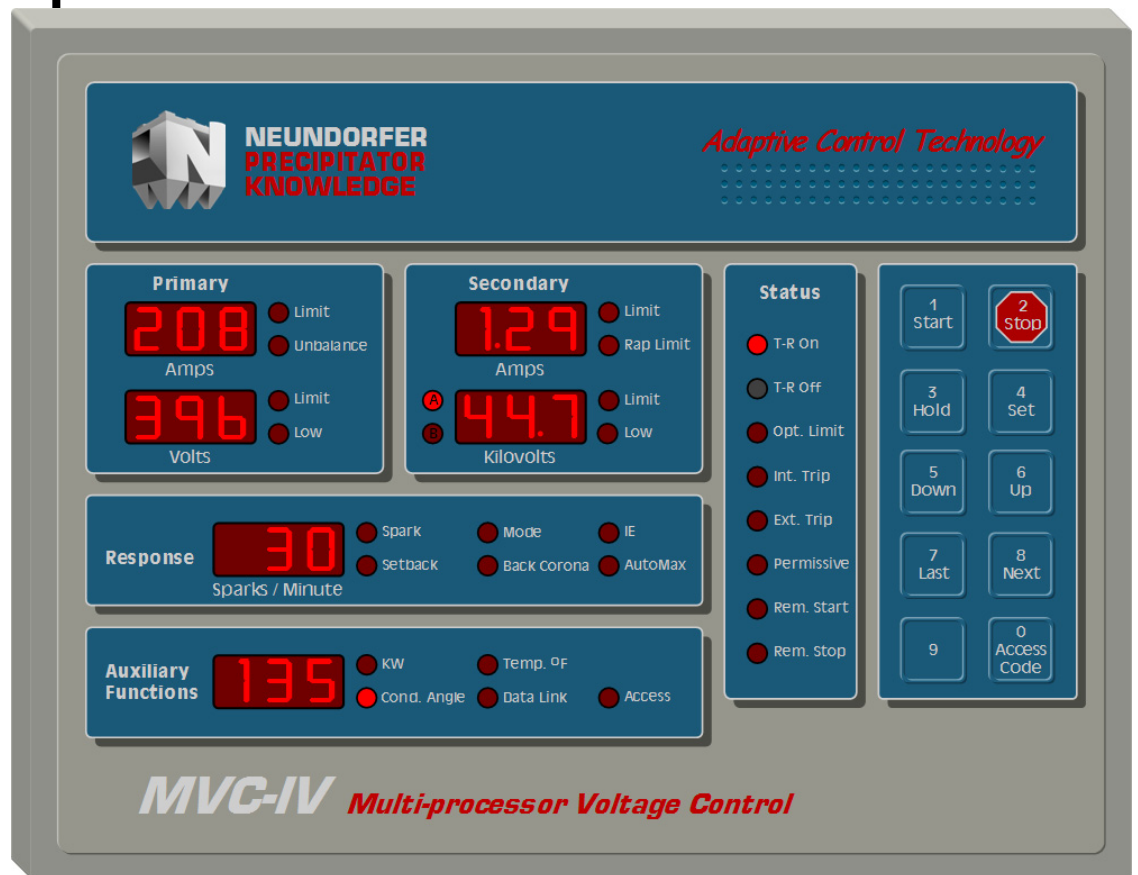

*Designed and Manufactured by:  
Neundorfer, Inc.  
4590 Hamann Parkway  
Willoughby, Ohio 44094  
440-942-8990  
Fax 440-942-6824  
<http://www.neundorfer.com>*





## TABLE OF CONTENTS

**SAFETY WARNINGS**..... vi

**ADDENDUM** ..... vii

**1.0 INTRODUCTION** ..... 1

    1.1 About this Manual ..... 1

    1.2 Introducing the MVC-IV ..... 2

    1.3 For a Successful Installation ..... 4

    1.4 Before Applying Power ..... 6

**2.0 THEORY OF OPERATION** ..... 7

**3.0 SOFTWARE** ..... 9

    3.1 License ..... 9

    3.2 Upgrades ..... 9

    3.3 Installing New Software ..... 10

    3.4 Software Identification ..... 10

**4.0 SPECIFICATIONS** ..... 11

    4.1 PCB Assembly & Serial Number ID ..... 11

    4.2 Inputs (To Interface Circuit Board) ..... 11

    4.3 Outputs (From Interface Circuit Board) ..... 14

    4.4 SCR Ratings ..... 14

    4.5 Logic System Temperature Rating ..... 14

**5.0 INSTALLATION AND WIRING** ..... 15

    5.1 General ..... 15

    5.2 Main T-R Power Supply ..... 15

    5.3 Grounding ..... 16

    5.4 Feedback Wiring

        5.4.1 Primary Current Feedback Signal Wiring ..... 16

        5.4.2 Primary Voltage Feedback Signal Wiring ..... 16

        5.4.3 Secondary Current Feedback Signal Wiring ..... 16

        5.4.4 KV Feedback Signal Wiring ..... 17

    5.5 SCR Gate Wiring ..... 18

    5.6 Complete Cabinet or Pre-Wired Back Panel Installation ..... 18

    5.7 Major Assembly Subsystems Retrofit Installation ..... 19

    5.8 Continuity Test ..... 19

**6.0 OPERATOR CONTROLS** ..... 21

    6.1 MVC-IV Readouts & Indicators ..... 21

    6.2 Keypad ..... 25

    6.3 T-R On Switch ..... 26



# MVC IV VOLTAGE CONTROL MANUAL

NEUNDORFER PRECIPITATOR KNOWLEDGE



<b>7.0</b>	<b>MVC-IV MODES .....</b>	<b>27</b>
7.1	Standby .....	27
7.2	Tripped .....	27
7.3	Operating.....	27
7.4	System Setup.....	27
7.5	Factory Calibration .....	28
<b>8.0</b>	<b>SOFTWARE CONFIGURATION .....</b>	<b>29</b>
8.1	Software Options Code .....	30
8.2	Setting T-R Primary CT Size .....	30
8.3	Setting T-R Secondary Maximum Allowed Current Limit .....	31
8.4	Setting KV Divider Values.....	32
8.5	Configuring Opto Coupler Inputs .....	33
<b>9.0</b>	<b>ADJUSTING LIMITS AND SETPOINTS .....</b>	<b>35</b>
9.1	Primary Current Limit .....	36
9.2	Primary Over voltage Limit .....	37
9.3	Primary Low voltage Limit .....	37
9.4	Secondary Current Limit .....	38
9.5	Rap Limit .....	38
9.6	Secondary KV Over Voltage Limit .....	39
9.7	Secondary KV <sub>a</sub> Low Voltage Limit / Bushing Enable .....	39
9.8	Secondary KV <sub>b</sub> Low Voltage Limit / Bushing Enable .....	39
9.9	Baseline Spark Rate .....	40
9.10	Setback .....	40
9.11	Spark Response Mode .....	41
9.12	Back Corona Control Software .....	42
9.13	IE Ratio Settings .....	43
9.14	AutoMax Settings .....	44
9.15	Kilowatts .....	45
9.16	Conduction Angle .....	45
9.17	Temperature .....	46
9.18	Data Link Unit Number .....	46
9.19	POS Access Enable .....	46
<b>10.0</b>	<b>ADDITIONAL FEATURES .....</b>	<b>47</b>
10.1	Operation of Auto Restart .....	47
10.2	Display Hold Feature .....	48
10.3	Dual Bushing Kilovolt Metering .....	48
10.4	Auxiliary Functions Display Default Parameter .....	48
10.5	Auto Spark Quench Interval .....	48
10.6	RS-485 Communications .....	49
10.7	Data Link Start, Stop, and Reset Commands .....	50
10.8	Remote Start, Remote Stop, and Ack Alarm Signals .....	50
10.9	Alarm Relays .....	51





# MVC IV VOLTAGE CONTROL MANUAL

NEUNDORFER PRECIPITATOR KNOWLEDGE



<b>11.0 INITIAL STARTUP .....</b>	<b>53</b>
11.1 Setting Circuit Board Jumpers .....	54
11.2 Initial Turn On Settings.....	56
11.3 Calibration - General Information .....	57
11.4 Primary Current Metering Check.....	57
11.5 Primary Voltage Metering Check.....	58
11.6 Secondary Current Metering Check.....	58
11.7 KV Metering Check .....	59
11.8 Final Checks .....	60
<b>12.0 OPERATING SETUP .....</b>	<b>65</b>
12.1 Suggested MVC-IV Setup .....	65
12.2 Normal Operation .....	68
<b>13.0 DISPLAY PANEL USER MANUAL .....</b>	<b>69</b>
13.1 Display Configurations .....	69
13.2 Display Operating Modes .....	69
13.3 Security Access Code.....	70
13.4 POS Access .....	72
13.5 LAN Display Unit Select .....	72
13.6 Display Panel Power On Self Test .....	73
13.7 Display Processor Service Setup Mode .....	73
13.8 Token Pass Network Display User Setup Mode .....	74
13.9 Setting MVC-IV Logic Processor Unit Number .....	74
<b>14.0 PCB JUMPERS, LED's, TEST POINTS, SWITCHES .....</b>	<b>75</b>
<b>and CONNECTORS</b>	
14.1 Main Logic PCB .....	75
14.2 Interface PCB .....	77
14.3 Display PCB .....	79
<b>15.0 TROUBLE SHOOTING .....</b>	<b>81</b>
15.1 Diagnostic Error Codes .....	81
15.2 MVC-IV Trouble Shooting Guide .....	85
15.3 MVC-IV Setup Problems .....	89
15.4 Identifying Operational Problems .....	90
15.5 Precipitator Trouble Shooting Guide .....	97
15.6 Data Link Trouble Shooting .....	99



# MVC IV VOLTAGE CONTROL MANUAL

NEUNDORFER PRECIPITATOR KNOWLEDGE



## FIGURES & ILLUSTRATIONS

Figure 1	MVC-IV Display Panel Item Identification .....	24
Figure 2	MVC-IV Display Panel Keypad .....	25, 35
Figure 3	MVC-IV Logic Board Jumper Identification .....	55
Figure 4	Spark Response Mode Waveforms .....	61
Figure 5	Auto Spark Quench Interval Waveforms .....	62
Figure 6	Primary Current Waveforms .....	63
Figure 7	SCR Gate to Cathode Waveform .....	64
Figure 8	MVC-IV Logic Board Component Identification .....	76
Figure 9	MVC-IV Interface Board Component Identification .....	78
Figure 10	MVC-IV Display Board Component Identification .....	79
Figure 11	RS-485 Differential Signal at 1 msec./div.....	99
Figure 12	RS-485 Differential Signal at 100 usec./div.....	100
Figure 13	RS-485 Data A (+) & B (-) with AC terminator at 100 usec./div.....	101
Figure 14	RS-485 Data A (+) & B (-) with DC terminator at 100 usec./div.....	101
Figure 15	RS-485 Differential Signal with failed driver at 100 usec./div.....	103
Figure 16	RS-485 Data A (+) & B (-) with failed driver at 100 usec./div.....	103

## TABLES

Table 1	Recommended CT's vs. T-R Primary Current .....	12
Table 2	SCR Ratings .....	14
Table 3	KV Circuit Configuration Jumpers .....	17
Table 4	Software Configuration Parameters .....	29
Table 5	Software Options Coding .....	30
Table 6	T-R Primary Current Range vs. CT .....	31
Table 7	Max T-R KV Limit vs. Divider .....	32
Table 8	Opto Input Channels & Connections .....	33
Table 9	Opto Inputs AND/OR Encoding .....	33
Table 10	Opto Inputs Function Encoding .....	34
Table 11	Auto Restart Operation .....	47
Table 12	Data Link Start/Stop Operation .....	50
Table 13	Remote Start / Stop Operation .....	50
Table 14	Initial Startup Setpoint Values .....	56
Table 15	MVC-IV Adjustable Parameters .....	65
Table 16	Logic Board Component Identification .....	75
Table 17	Interface Board Component Identification .....	77
Table 18	Display Board Component Identification .....	79
Table 19	Display Processor Diagnostic Error Codes .....	81
Table 20	Logic Processor Diagnostic Error Codes .....	82
Table 21	Diagnostic Code Trouble Shooting Guide .....	83-84
Table 22	MVC-IV Operational Problem Trouble Shooting Guide .....	85-88
Table 23	MVC-IV Setup Problem Trouble Shooting Guide .....	89
Table 24	Precipitator Trouble Shooting Guide .....	97-98



## APPENDIX

### A. CURRENT MONITOR RELAY SETUP INSTRUCTIONS & DATA SHEET

### B. FIBER OPTIC MODEM SETUP INSTRUCTIONS & DATA SHEET

### C. STANDARD DRAWINGS

8-01-0222	Wiring Diagram, Data Link Network & POS, MVC4 Configuration
8-01-0223 (Sheets 1 & 2)	Schematic Diagram, Dual Bushing MVC4 (Generic)
8-01-0224	Connection Diagram, MVC4 Retrofit (Generic)
8-01-0225	Wiring Diagram, MVC4 Cabinet (Generic)
8-01-0229	Interface Board Connections, MVC4 (Generic)
8-01-0230	Logic Board Connections, MVC4 (Generic)
8-01-0226	Cabinet Layout, MVC4 Standard
8-01-0232 (Sheets 1 & 2)	Outline & Drill Template, MVC4 Display
82200-104	Outline, KV Signal Feedback Surge Suppression PCB

### D. CUSTOM AS BUILT AND INSTALLED DRAWINGS

(Some may be supplied under separate cover)

Equipment Layout (for cabinets) or  
Scope of Supply (for retrofits)  
System Schematic, As Built  
System Wiring Diagram, As Built

### E. RECOMMENDED SPARE PARTS LIST

(May be supplied under separate cover)



# MVC IV VOLTAGE CONTROL MANUAL

NEUNDORFER PRECIPITATOR KNOWLEDGE



## SAFETY WARNINGS

Voltage control cabinets, T-R sets and precipitators all contain sources of lethal voltage. Only personnel with appropriate safety training should attempt to perform any work on these systems. Follow all applicable plant safety regulations when working on this equipment.

There are four types of warning boxes in this manual. Always read and obey all safety messages.

### **DANGER**

**DANGER** indicates an imminently hazardous situation that, if not avoided, will result in death or serious injury.

### **WARNING**

**WARNING** indicates a potentially hazardous situation that, if not avoided, could result in death or serious injury.

### **CAUTION**

**CAUTION** indicates a potentially hazardous situation that, if not avoided, may result in minor or moderate injury.

### **CAUTION**

**CAUTION** used without the safety alert symbol indicates a potentially hazardous situation that, if not avoided, may result in property damage.



# MVC IV VOLTAGE CONTROL MANUAL

NEUNDORFER PRECIPITATOR KNOWLEDGE



## ADDENDUM

This page is for future use.



# MVC IV VOLTAGE CONTROL MANUAL

NEUNDORFER PRECIPITATOR KNOWLEDGE



This page intentionally blank.



## 1.0 INTRODUCTION

### 1.1 About This Manual

This manual covers installation, operation, and troubleshooting procedures which can be performed by customer personnel who operate and maintain the MVC-IV control.

It is recommended that the personnel installing the MVC-IV read and understand the contents of *sections 4 and 5* as well as the system drawings and schematics before starting installation.

*Sections 6 through 13* should be thoroughly understood by personnel operating the MVC-IV to ensure personal safety and equipment protection.

*Sections 14 and 15* provide technical information for the personnel responsible for maintenance of the MVC-IV.

The technical staff at Neundorfer Inc. always invites commentary on our manuals in an effort to improve or clarify their contents. Please feel free to contact us at:

**Neundorfer, Incorporated**  
**4590 Hamann Parkway**  
**Willoughby, Ohio 44094**  
**Phone 440-942-8990**  
**Fax 440-942-6824**  
**<http://www.neundorfer.com>**



# MVC IV VOLTAGE CONTROL MANUAL

NEUNDORFER PRECIPITATOR KNOWLEDGE



## 1.2 Introducing the MVC-IV

The **MICRO VOLTAGE CONTROL IV (MVC-IV)** is an advanced microprocessor T-R controller designed for easy installation and use. It features large dedicated LED digital readouts and other illuminated indicators to set and verify operating functions. It can communicate with the Neundorfer MicroRap rapper control and the Neundorfer PC based Precipitator Optimization System (POS) over an RS-485 data link network as part of a unified precipitator control system. The POS software provides remote control, plan view displays, data logging and Energy management.

The MVC-IV is available as a complete stand alone factory wired cabinet, as a retrofit with a pre-wired backpanel using the customer's existing compatible equipment (requiring customer interface wiring) or as major assembly subsystems for customer installation and wiring.

The MVC-IV is based on Freescale (formerly Motorola) single-chip microcontroller units (MCUs). The main **LOGIC** MCU has approximately 10 times the throughput capability of the predecessor MVC-III MCU. The **LOGIC** MCU samples the primary current, primary voltage, secondary current, secondary voltage, and spark inputs every 521 microseconds. From these collected samples sophisticated waveform analysis is performed every half cycle of the line (8.33 msec) to determine adjustments in the SCR gate firing program for the next half cycle and in some cases for the present half cycle.

The speed of the MVC-IV enables the control to adjust quickly and accurately to changing conditions in the precipitator, and provides the user with precise information about T-R set operation. If a condition exists, such as a shorted electrical field due to a broken discharge electrode, that the MVC-IV cannot control or correct, it will shut itself off and freeze the **DISPLAY** panel. With the **DISPLAY** frozen, the operator can identify the condition that caused the control to shut down.

The MVC-IV Display Panel

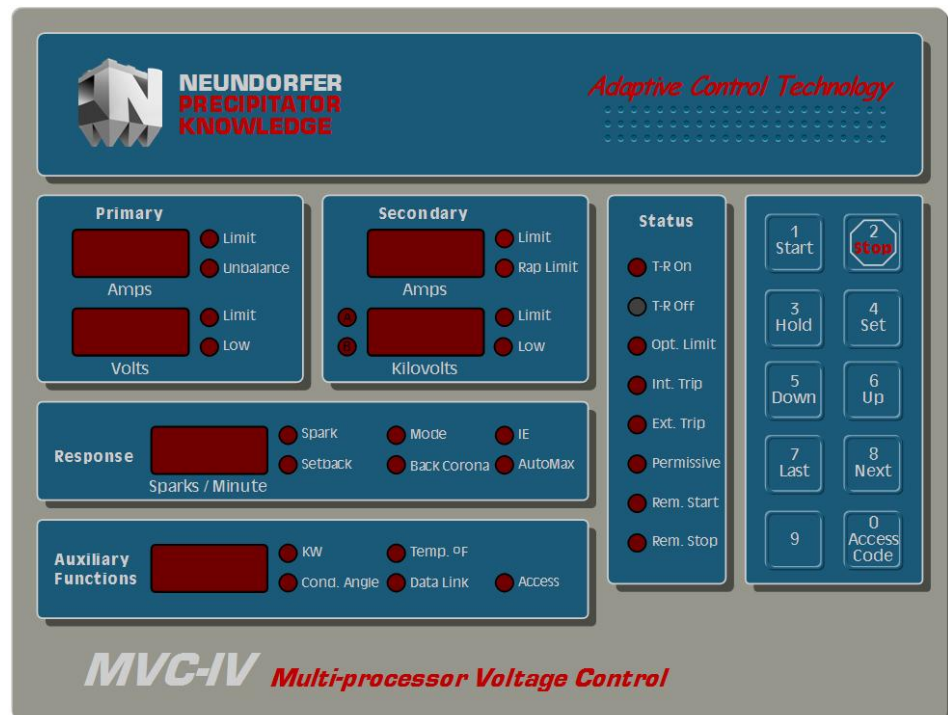





## 1.2 Introducing The MVC-IV (cont)

The MVC-IV employs advanced hardware designs and increased use of self adaptive software algorithms to improve the collection efficiency of electrostatic precipitators. This fourth generation controller builds on the vast knowledge gained from over 6000 MVC II and MVC-III systems in service to provide a more capable controller that is easier to install and safer to maintain. Some significant enhancements are:

### General Enhancements

- Multi-processor design. The **DISPLAY** incorporates its own processor that communicates with the **LOGIC** over an RS-485 network. The **DISPLAY** may be in the same cabinet with the **LOGIC** or it may be 1000 feet away, such as in a Joy cubicle.
- Surface mount technology **LOGIC** and **DISPLAY** boards for reduced size and increased reliability.
- Smaller size, easier installation and no calibration requirement for reduced total installed cost and safer startup.
- Three PC board system with plug connections to all boards for quick board swaps. Standard LAN cable connects **LOGIC** to **DISPLAY**.
- Absence of calibration adjustments enables quick board swaps. There is no need to ever open an energized cabinet.
- No requirements for periodic re-calibration.
- Can accommodate 30-640 Amps primary current, 0-3200 mA. secondary current and 0-120 KV with 40-400 Meg dividers.
- Can be configured without **DISPLAY** panel. All operating setpoint adjustments are accessible from the POS terminal. A portable **DISPLAY** can provide local readout when needed and is required to set the individual controller unit numbers.

### Technical Enhancements

- Programmable gain analog inputs and highly accurate analog circuitry eliminate all calibration adjustments.
- **INTERFACE** board provides precision primary and secondary T-R current metering resistors for accurate measurement.
- Faster microprocessors (10 x MVC-III speed) support more complex performance enhancing control algorithms.
- Proprietary **NON LINEAR RAMPING** algorithm increases precipitator power levels.
- **ADAPTIVE CONTROL TECHNOLOGY** improves precipitator performance by eliminating need for retuning as process conditions change.
- Enhanced spark detection and response algorithms improve precipitator collection under difficult or abnormal conditions.
- 57,600 baud data link speed triples communications speed with POS or DCS.
- Supports POS optimization of all operating parameters and POS managed precipitator start up and shutdown.
- High speed 200 Volt common mode input differential amplifiers enhance capability to extract accurate T-R feedback signals from the background electrical noise for improved waveform analysis.
- Proportional current limit algorithms provide fast response to precipitator transients reducing possibility of SCR fuse clearing or SCR damage on retrofits with marginal rated SCR's.



# MVC IV VOLTAGE CONTROL MANUAL

NEUNDORFER PRECIPITATOR KNOWLEDGE



## 1.3 For a Successful Installation

Proper connection of power, control ground and T-R set feedback signals is paramount for correct control operation and accurate T-R set metering.

The SCR gate wiring and Secondary Current feedback wiring carry especially high transients that can act as an RF transmitter adversely affecting control operation. Follow neat wiring practices that avoid running T-R feedback signals parallel with SCR gate signals and T-R primary wiring. Dress all connecting wires straight out at least several inches away from the **INTERFACE** board before running parallel to the boards. Do not bundle the communication cables connected to the **LOGIC** board with the cables attached to the **INTERFACE** board.

### 1.3.1 Power Feed

The power feed to the MVC-IV controller and T-R set must be ground referenced. It cannot be a floating source. Typically the power source will be single phase 480 to 600 VAC derived across two legs of a three phase grounded neutral power main. If the power feed is from a single phase source, the neutral must be grounded and the neutral must connect to the T-R set rather than to the SCR - CLR. See [section 5.2](#) for more details.

### 1.3.2 Controller Grounding

The system drawings specify several **INTERFACE** board terminals that must be connected to earth ground. Provide a **separate run of AWG 14 wire** from each of these terminals to the earth ground bar in the control cabinet. *J1-terminals 3 and 4* may be combined onto one wire run. Do not daisy chain any of the other terminals together at the **INTERFACE** board.

Ensure that the ground bar is properly bonded to the building earth ground system. See [section 5.3](#) for more details.

### 1.3.3 T-R Set Feedback Wiring

#### **WARNING**

**Failure to provide surge suppressors to ground on the Secondary Current and KV feedback signals at the source can cause lethal voltages and currents to be present on the feedback wiring!**

The MVC-IV controller uses precision metering circuits to accurately measure T-R set operating parameters. It must be understood that **all** of the signal being monitored must be presented to the **INTERFACE** Board to preserve accuracy.

This is not a problem for Primary Current and Voltage as **Primary Current** is monitored by a dedicated CT, and **Primary Voltage** is read directly across the T-R set primary. Secondary Current and KV, however, will typically require reworking existing metering circuitry.

**Secondary Current** and **KV** are both measured as currents. Any circuitry that allows current to flow directly to ground without first flowing through the **INTERFACE** board sense inputs will introduce errors in the control's readings. Compliance with this requirement is usually not an issue unless the installation involves retaining existing analog meters. Analog meters often have filtering and signal division (calibration) circuits that may be split between the T-R set low voltage junction box and the control cabinet, and often have multiple ground paths. In that case, all circuitry must be moved from the low voltage junction box to the control cabinet with all ground paths combined into one circuit for each signal which then connects to ground only through the respective **INTERFACE** Board input. See [section 5.4](#) for more details.

For KV feedback, there are two possible wiring methods, **Balanced** and **Unbalanced**.



*Balanced* KV feedback wiring provides the best signal fidelity and is necessary for advanced software algorithms but requires a dedicated twisted pair cable. See [section 5.4.4](#) for more details.

*Unbalanced* KV feedback wiring is used when existing wiring must be reused, and there is not a dedicated pair of wires for KV. This is common in retrofits where there is a single milliamp signal wire, a single KV signal wire and a single shared return wire. See [section 5.4.4](#) for more details.

All Secondary Current and KV metering ground paths in the low voltage junction box must be removed leaving only surge protectors from the signal connections to ground. **Since the surge protectors are the only ground path at the Secondary Current and KV source, it is imperative that they be installed.** Without them, if the feedback wiring becomes disconnected from the interface board, which provides the only ground path, full T-R set potential could appear on the feedback wiring.

### 1.3.4 About Shielded Cables

Shield continuity must be maintained for the entire length of the cable run and isolated from all ground contact except at the ends. The **INTERFACE** board provides individual shield grounding terminals for Primary Current, Secondary Current, KV<sub>a</sub> and KV<sub>b</sub> signal cables. Shielded cable application theory teaches that the shield should be connected to ground only at one end (the **INTERFACE** board end). We have found, however, that shielded cables used for Secondary Current and the KV signals may perform better when the shield is also connected to ground at the T-R set end. Use the shield connection configuration that provides the cleanest signals as observed on an oscilloscope.

Do not use shielded cables for the SCR gate signal. Instead use a tightly twisted pair of unshielded wires rated for 600 VAC operation, no more than 3 feet long, and routed well away from the MVC-IV circuit boards.



# MVC IV VOLTAGE CONTROL MANUAL

NEUNDORFER PRECIPITATOR KNOWLEDGE



## 1.4 Before Applying Power

### **! WARNING**

**Voltages and currents capable of causing death are present in the T-R control cabinet and at the T-R set!**

No one should attempt to operate this equipment who does not have a through knowledge of all required safety procedures.

Improper operation of this equipment could result in injury or death and damage to the MVC-IV, T-R set or precipitator. Before applying power to the MVC-IV system for the first time:

- Verify continuity and correctness of all connections.
- Verify all connections are tight and properly insulated.
- Verify proper grounding of T-R set and MVC-IV logic system. *See section 5.3.*
- Verify proper configuration of all circuit board jumpers. *See section 11.1.*
- Open the **T-R On** switch.
- Power up the MVC-IV control into the System Setup Mode with the **T-R On** switch in the open position. *See section 8.0.*
- Set the **Software Options Code, T-R Primary CT Size, T-R Maximum Secondary Current, KV Divider** values and **Opto Coupler Input Configurations** as indicated in *sections 8.1 - 8.5.*

- Referring to *section 9*, set the MVC-IV limits as follows:

**Primary Current Limit** ----- 50% of T-R rating  
**Primary Over Voltage**----- T-R nameplate  
**Primary Under Voltage** ----- 80 Volts  
**Secondary Current Limit** ---- 50% of T-R rating  
**Rap Limit**----- 0.0 Amps  
**KV Over Voltage Limit** ----- T-R rating - 10 KV  
**KV Under Voltage Limit** ----- 8 KV  
**Baseline Spark Rate** ----- 15 SPM  
**Setback**----- 5%  
**Spark Response Mode** ----- 1  
**Back Corona Adjust**----- OFF  
**IE Ratio** ----- OFF  
**AutoMax**----- OFF  
**Conduction Angle**----- 30 degrees  
**Data Link Unit Number** ----- sequential  
**POS Access Enable** ----- OFF

- Be sure to set the Conduction Angle Limit to 30°. *See section 9.16.*  
*This setting is critical to protect the T-R set when it is initially energized.*
- Remove power from the MVC-IV control for about 10 seconds, then reapply power and verify that all software configuration codes and setpoint limits have been retained.
- You are now ready to follow the startup procedure outlined in *section 11.*



## 2.0 THEORY OF OPERATION

The Neundorfer MVC-IV is designed to maintain the highest possible precipitator collection efficiency by maximizing the instantaneous high voltage applied to the bus section and minimizing response and recovery time to sparking. MVC-IV prevents arcing, which can damage the precipitator and reduce collection efficiency. Since conditions in a precipitator continually change, the applied voltage must be adjusted continuously to achieve maximum efficiency.

The maximum voltage that can be applied to a precipitator is determined by the spark over voltage between the discharge electrodes and the collecting plates. When the voltage applied to a precipitator approaches the point at which the flue gas filled space between the wires and plates breaks down, sparking occurs. The term “spit spark” refers to a momentary breakdown from which the precipitator recovers rapidly with little effect on precipitator operation. In most cases a spit spark will self extinguish. When the momentary breakdown produces a channel of ionized gas between the precipitator electrodes of sufficiently low impedance to permit large currents to flow, the result is called a “spark”. A sustained spark lasting for more than a few half cycles of the line is called an “arc”.

The Neundorfer MVC-IV maintains the optimum voltage by continuously monitoring the T-R feedback signals for indication of an impending arc. If an arc is imminent, the power is removed from the T-R set primary before a damaging arc can develop. After a brief quench interval, the MVC-IV then rapidly increases the T-R primary current and voltage to re-apply power to the bus section.

*Figure 4a* shows typical control response to sparking. After a spark, there is a brief quench interval during which power is removed from the T-R set primary. Then power is rapidly ramped up to the Post Spark Setback level. The control then enters the slow ramp phase until the next spark occurs or an operating limit is reached. The MVC-IV’s self adaptive software dynamically

adjusts the shape and duration of each of the response intervals as needed for maximum collection efficiency.

To achieve maximum precipitator efficiency, the MVC-IV performs three major functions: T-R set electrical feedback sensing, processing, and controlling.

### T-R Set Electrical Feedback Sensing

The MVC-IV rapidly samples analog input signals from the T-R set primary and secondary current and voltage feedback signals to calculate instantaneous operating levels and determine occurrences of sparking. Primary voltage and current are calculated as RMS values while the secondary values are calculated as average DC to agree with T-R nameplate labeling convention.

The MVC-IV has the capability to monitor both bushings of a dual bushing T-R set. Secondary voltage feedback is necessary for KV limiting, enhanced spark detection algorithms, and operation of Back Corona Control and POS V-I curve features. If these features are not needed, the MVC-IV can be operated without secondary voltage feedback.

Primary current feedback and Zero Cross timing signals are provided by electrically isolated transducers. Primary voltage feedback utilizes precision 1000:1 voltage dividers and a fully differential input to safely monitor primary voltage. Secondary feedback is via special operational amplifiers capable of withstanding up to 200 volts of common mode input signal. The secondary feedback circuits provide transient noise filtering and suppression.

Primary current, secondary current and KV input channels employ programmable gain amplifiers adjusted in real time by the microcontroller to set signal gains as need for the particular range of signals and transducers.





## 2.0 THEORY OF OPERATION (con't)

### Processing

The microcontroller continually processes the T-R feedback signals using circuitry, operator setpoint adjustments, and the software program to generate optimally timed SCR gate turn on signals. The gate circuitry converts the SCR turn on signal into trigger pulses which fire the SCR's supplying power to the primary side of the T-R set.

After each full line cycle of *actual SCR conduction*, the Microcontroller calculates the primary RMS current and voltage and the average DC secondary current and voltage(s) for that period. The values are checked against the setpoint limits to modify T-R set power input (SCR gate firing signal) as need to correct any over limit conditions.

This process automatically ensures correct T-R set operating limit control under all operating conditions, including Intermittent Energization. The line cycle values are time averaged and displayed on the front panel. Transient conditions trigger front panel status indicators.

### Controlling

Controlling the precipitator secondary voltage and current is accomplished by controlling the conduction angle of the primary power applied to the T-R set. After receiving the trigger pulses from the firing circuit, the SCR's act as switches that conduct for the remaining portion of each half cycle of the power line. The MVC-IV controller regulates the conduction angle as necessary to maintain T-R operation near the sparking threshold and within the T-R voltage and current setpoint limits.

The principle method of spark sensing is based on a feedback signal derived from the T-R set secondary current signal. Sparking usually causes a fast rise high current transient in the secondary current which is interpreted as a spark. There are some arc conditions that slowly develop without the expected transient. These occurrences are detected using primary current, primary voltage and KV

(if available) analysis algorithms. For KV based spark sensing feature to function the low pass filter jumpers, JP71 and JP81, on the **LOGIC** board must be removed or placed in the storage position.

Spark sensing does not require operator adjustments or calibration.

User selectable Spark Response Modes enable the user to tailor the controller's response to sparking for the particular application. The most commonly used Spark Response Mode (see *figure 4a*) quenches each spark by momentarily interrupting power flow to the T-R set. Then the operating voltage is rapidly increased to the Setback level followed by a slow ramp up to the next spark or operating limit. Other spark response modes may invoke a setback with no quench or a quench with no setback on the first spark event, providing the full response only if there is another spark on the following half cycle. The exact spark response pattern is determined by the Spark Response Mode, Baseline Spark Rate, Setback, and self adaptive software algorithms.

The MVC-IV includes Intermittent Energization (IE) and Back Corona Control software. Intermittent Energization can improve precipitator performance and significantly reduce energy consumption in many applications.

Back corona is an undesirable operating condition that can reduce collection efficiency and increase power consumption. Back Corona Control software maintains the maximum operating level possible below the onset of back corona. The algorithm senses back corona by analysis of enabled KV bushings. For this feature to function the low pass filter jumpers, JP71 and JP81, on the **LOGIC** board must be removed or placed in the storage position. If the algorithm senses back corona, it responds by initiating a four half cycle quench and a setback. The effect is to limit T-R operation to a point just below the onset of back corona.



# MVC IV VOLTAGE CONTROL MANUAL

NEUNDORFER PRECIPITATOR KNOWLEDGE



## 3.0 SOFTWARE

### 3.1 Software License

The MVC-IV LOGIC and DISPLAY boards contain computer programs “software,” which are copyrighted products. The owner of the MVC-IV controller is granted a license to operate the computer program in the MVC-IV controller in which it was originally supplied. Duplication or alteration, in part or in whole, of the program or reverse engineering the program is prohibited by United States copyright law.

### 3.2 Software Upgrades

Neundorfer, Inc. may make future changes in the MVC-IV computer program to enhance operation or add features. While Neundorfer, Inc. is under no obligation to modify or upgrade customers’ controllers with such new programs, it is company policy to provide updated software free of charge upon request for the life of the equipment. The customer is responsible for all installation and related charges. New programs may be provided in file format for the customer to program into the controllers. In that case the customer will be granted the right to duplicate the supplied file format program to provide one copy for each owned MVC-IV.

- V2.0a 12/13/2007 – Add V-I Curve feature. Revise system error handler.
- V2.1a 02/27/2008 – Revise allowed settings for Primary Current limits vs. CT value to reflect low VA rating of CT's smaller than 150:5.
- V2.1b 04/10/2008 – Revise POS Access Enable "OFF" setting to disconnect RS-485 circuitry from the POS data lines. Terminator, if enabled, remains in circuit.
- V2.1d 07/09/2009 - Revise Unbalance detection for improved reliability. Improve accuracy of RMS calculations. Detail improvements in Oscilloscope operation and reduction in CPU overhead.

#### 3.2.1 Major Software Upgrade Features

- V1.4b 06/02/2006 – First production program.
- V1.4c 07/27/2006 – Correct error in POS message \$28 / \$29 processing.
- V1.4d 01/09/2007 – Correct SPM setpoint error. Implement changes for latest MCU errata. Corrected data link lockup problem.
- V1.4e 03/09/2007 – Block remote display from changing unit number.
- V1.4f 07/05/2007 – Correct Display UART error handler problem that caused inappropriate control shutdown on error detection.



# MVC IV VOLTAGE CONTROL MANUAL

NEUNDORFER PRECIPITATOR KNOWLEDGE



### 3.3 Installing New Software

The MVC-IV microcomputer maintains error check data in its non-volatile memory to verify program integrity. When the software program is changed, the new program may be detected as defective. The MVC-IV may halt with an error code of 1.3.1. in the **Auxiliary Functions** display. The microcomputer must be instructed to accept the new memory contents as valid by entering System Setup Mode and pressing the **Set** key. Then press the **Stop** key to exit System Setup Mode. *See section 8.0 steps 1-5, 8 and 9.*

### 3.4 Software Identification

The MVC-IV software program is stored within the FLASH and EEPROM memory in the MCU main LOGIC board. The software version is available from POS. *Please have the software version number available when calling Neundorfer for assistance.* The software version is coded as follows. The "MVC4" portion is optional:

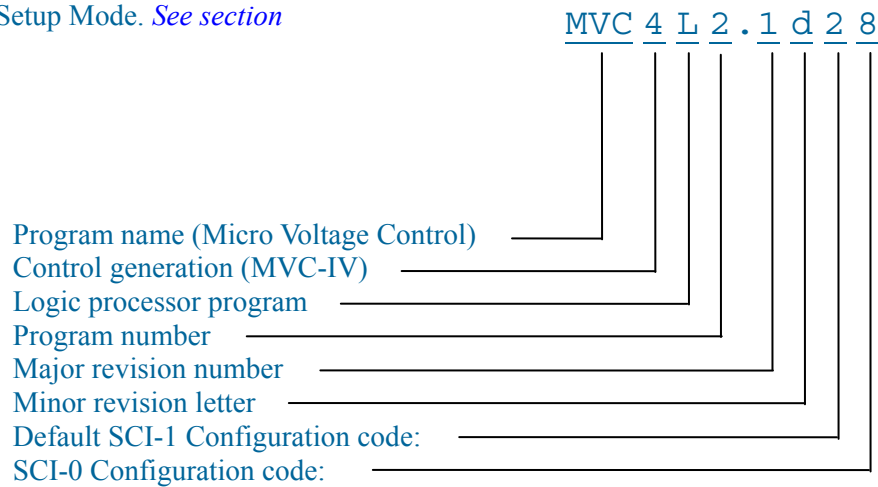

SCI-1 is normally assigned to POS communications, but may be re-assigned (*Planned feature, subject to change. Not yet available*) for a second display communications network if there is no POS communications requirement. *Re-assignment is made in Software Options Code (Planned feature, subject to change. Not yet available.* If SCI-1 is re-assigned to a display network, it will be forced to operate at the same baud rate as SCI-0.

- SCI-1 Configuration code:
- 0 = 8-bit POS protocol @ 19,200 baud
  - 1 = 8-bit POS protocol @ 38,400 baud
  - 2 = 8-bit POS protocol @ 57,600 baud (standard)
  - 3 = 8-bit POS protocol @ 76,800 baud
  - 4 = 8-bit POS protocol @ 115,200 baud
  - 5 = Unused
  - 6 = 9-bit Display protocol @ 38,400 baud
  - 7 = 9-bit Display protocol @ 57,600 baud
  - 8 = 9-bit Display protocol @ 76,800 baud
  - 9 = 9-bit Display protocol @ 115,200 baud

- SCI-0 is always dedicated to the 9-bit display communications network.
- SCI-0 Configuration code:
- 6 = 9-bit Display protocol @ 38,400 baud
  - 7 = 9-bit Display protocol @ 57,600 baud
  - 8 = 9-bit Display protocol @ 76,800 baud (standard)
  - 9 = 9-bit Display protocol @ 115,200 baud





# MVC IV VOLTAGE CONTROL MANUAL

NEUNDORFER PRECIPITATOR KNOWLEDGE



## 4.0 SPECIFICATIONS

### 4.1 PCB Assembly & Serial Number ID

Each of the printed circuit boards in the MVC-IV system has an etched PCB number and Revision letter, a silk screened Assembly Designation, an optional Assembly Revision and an individually applied Serial Number. Refer to *figures 8 - 10* for placement of the ID numbers on the various MVC-IV printed circuit boards.

*Please have the main LOGIC board assembly number, assembly revision, serial number and software version number available when calling Neundorfer for assistance or spare parts.*

### 4.2 Inputs (To Interface Circuit Board)

#### 4.2.1 Analog Input Signals Required for Operation *(except as noted)*

- Grounding: ----- A properly bonded earth ground is required for reliable operation of the MVC-IV control system and data link network. Each designated ground terminal on the **INTERFACE** board connectors must be connected to the ground bus in the control cabinet using AWG 14 wire.
- Logic power: ----- 120 VAC, +10%, -15% (102 V - 132 VAC), single phase, 60 Hz, 3/10 amp. Must be supplied from same phase supplying the T-R set. *If the system does not have a main line contactor and uses K3 to trip the T-R supply breaker for a run away condition, then the control power should be from a source ahead of the T-R supply breaker.*
- T-R Power source:----- 480 - 600 VAC, 59.5 to 60.5 Hz.
- Primary Current (PI): ----- 2.0 - 4.5 Amps RMS at maximum primary current. Usually supplied by an XXX : 5 current transformer. The **INTERFACE** PCB provides the CT burden resistor and can accommodate signals up to 4.5 Amps at maximum T-R set nameplate current. See *table 1* for recommended CT sizing. **Both current transformer leads must be isolated from ground.**

**CAUTION**

**Primary Current input signal above 4.5 AAC may cause failure of INTERFACE board components.**



# MVC IV VOLTAGE CONTROL MANUAL

NEUNDORFER PRECIPITATOR KNOWLEDGE



## 4.2.1 Analog Input Signals Required for Operation (con't)

Primary Current for CMR: ----- Input from CMR CT recommended in *table 1*. The CMR (CMR is optional) is an optional over current relay that operates independently from the MVC-IV LOGIC. It is not required for operation.

T-R Pri Current Nameplate	Recommended Pri Current & CMR CT	Min VA Output Rating
20 - 32	<b>50:5</b>	<b>2.0</b>
24 - 38	60:5	2.0
<b>30 - 48</b>	<b>75:5</b>	<b>2.0</b>
<b>49 - 64</b>	<b>100:5</b>	<b>2.0</b>
60 - 85	120:5	2.5
63 - 89	125:5	2.5
<b>65 - 135</b>	<b>150:5</b>	<b>5.0</b>
100 - 180	200:5	5.0
<b>125 - 225</b>	<b>250:5</b>	<b>10</b>
150 - 270	300:5	10
200 - 360	400:5	10
<b>226 - 450</b>	<b>500:5</b>	<b>10</b>
300 - 540	600:5	10
<b>375 - 640</b>	<b>750:5</b>	<b>10</b>
400 - 640	800:5	10
<b>500 - 640</b>	<b>1000:5</b>	<b>10</b>
600-640	1200:5	10

**Table 1 - Recommended CT's vs. T-R Primary Current**  
Common sizes are listed in bold.

Primary Voltage (PV): ----- 0 - 600 VAC RMS direct from T-R set primary. Maximum potential at either PV input above earth ground is 480 VAC

Secondary Current (SI): ----- 0 - 3.20 ADC from positive leg of T-R set secondary bridge rectifier. All T-R secondary current must flow through the INTERFACE board for accurate metering.

**CAUTION**

**Secondary Current input signal above 3.2 ADC may cause failure of INTERFACE board components.**



## 4.2.2 Recommended Analog Input Signals

Secondary Voltage (KV):----- KV input circuit can accommodate feedback signals from 40 to 400 meg voltage dividers for single or dual bushing T-R sets. Although not required for basic operation, the KV feedback signal protects the T-R set from damage caused by secondary over voltage, and it is required for several of the MVC-IV advanced software features.  
*(Optional input)*

## 4.2.3 Digital Input Signals Required for Operation

*If unused must be replaced with a bypass jumper. See drawing 8-01-0223, sheet 2.*

- Run Request: ----- Dry contact rated for 120 VAC (or bypass jumper)
- Customer Permissive:----- Dry contact rated for 120 VAC (or bypass jumper)
- CMR:----- Dry contact rated for 120 VAC (or bypass jumper)
- Contactor closed status: ----- Dry contact rated for 120 VAC (or bypass jumper)

## 4.2.4 Optional Digital Input Signals

*If unused leave unconnected. See drawing 8-01-0223, sheet 2.*

- Reduced Power Rapping: ----- 120 VAC or DC or dry contact (maintained)
- Acknowledge (Ack) Alarm: ----- 120 VAC or DC or dry contact (momentary)
- External Trip: ----- 120 VAC or DC or dry contact (maintained or momentary)
- Remote Stop: ----- 120 VAC or DC or dry contact (maintained or momentary)
- Remote Start: ----- 120 VAC or DC or dry contact (maintained or momentary)
- Data Link Networks:----- Half duplex RS-485 multi-drop communications network using 20 AWG or larger twisted pair shielded cable. Isolation, preferably by fiber optic cable, is required between control rooms.

## 4.2.5 Digital Input Signal Specifications

The digital inputs are opto coupler circuits with an impedance of 22.4K Ohms. They will accept either AC or DC signals. At a nominal 120 V, the input current is 5.25 mA.

ON or Activated threshold: ----- Above 77 VDC or 77 VAC

OFF or Deactivated threshold: ----- Below 1.0 mADC (23.3 VDC) or 1.27 mAAC (31.8 VAC).

If the digital inputs are driven by solid state relay outputs from a device such as a PLC, to avoid false on states, the SSRLY output OFF state leakage under worst case temperature conditions must be less than the above OFF threshold specification. In addition, ensure that the nominal 5.25 mA input current is at least double the holding current (minimum current specification) of the SSRLY outputs. If these conditions cannot be satisfied, parallel the MVC-IV digital inputs with appropriate load resistors or use relay outputs instead of SSRLYs.



# MVC IV VOLTAGE CONTROL MANUAL

NEUNDORFER PRECIPITATOR KNOWLEDGE



## 4.3 Outputs (From Interface Circuit Board)

### 4.3.1 Outputs Required for Operation

SCR Gate Firing: ----- Dual 2 Amp pulsed DC, 8 kHz outputs, transformer isolated.

Run Enable (K1) ----- 120 VAC, 3 Amp rated relay (contactor coil power)

Trip Alarm (K2): ----- SPDT, 8 Amp @125 VAC / 24 VDC, 1/3 HP @125 VAC

General Alarm (K3): ----- SPDT, 8 Amp @125 VAC / 24 VDC, 1/3 HP @125 VAC

Trip Circuit Breaker (K3): ----- SPDT, 8 Amp @125 VAC / 24 VDC, 1/3 HP @125 VAC  
(Alternate K3 configuration, user selectable)

## 4.4 Table 2 - SCR Ratings

Size Code	Amps RMS @ 70° C	Amps RMS @ 40° C	1200 VAC P/N	1800 VAC P/N
3	60	88	84800-073	Not Available
4	120	160	84800-009	84800-809
4	120	160	Not Available	84800-870
4+	185	250	84800-008	84800-808
5	260	350	84800-010	84800-810
5+	320	450	84800-011	84800-811
6	440	700	84800-038	84800-838
7	735	1140	84800-020	84800-820

## 4.5 Logic System Temperature Rating

Storage temperature: ----- -55° C to + 85° C.

Operating temperature: ----- -40° C to + 85° C.



## 5.0 INSTALLATION AND WIRING

### 5.1 General

The MVC-IV is available as:

- a complete stand alone factory wired cabinet
- a retrofit with a pre-wired backpanel to interface with the customer's existing compatible equipment
- major assembly subsystems for customer installation and wiring.

Sound mechanical installation and proper grounding are essential for a successful installation. Avoid running feedback signals parallel with SCR gate signals and T-R primary wiring.

Each component must be securely anchored to avoid any possibility of movement or damage to wiring. Cabinets, unless weatherproof design, should be protected from ingress of water, oil, dust, or any other contaminants that may be present. Placement of the MVC-IV in a non sealed cabinet inside an electrical control center room is acceptable if there are no airborne corrosives and dust infiltration is minimal.

To install the MVC-IV, refer to *sections 5.2 - 5.5* for wiring information. *Sections 5.6 - 5.8* provide specific information for different types of installations. Ensure that all safety precautions are observed. Lock out all power feeds, and ground all applicable bus sections. Neundorfer, Inc. can provide complete installation services or, for customers who wish to install their own controls, we can provide any level of technical direction desired.

### 5.2 Power Feed

The power feed to the MVC-IV controller and T-R set must have a ground reference. It cannot be a floating source. Typically the power source will be single phase 480 to 600 VAC derived across two legs of a three phase grounded neutral power main.

Verify proper neutral grounding by measuring the voltage from each feed line to earth ground. The reading should be equal for both feed lines and should be 277 VAC for a 480 Volt feed and 346 VAC for a 600 Volt feed. Actual reading to ground for both feed lines should equal (measured line-to-line voltage)/1.732.

If the power feed is from a single phase source, the neutral must be grounded and the neutral must connect to the T-R set rather than to the SCR - CLR.

Regardless of power feed source configuration, the maximum voltage from either feed line to earth ground must not exceed 480 VAC.

The zero cross reference used for phase firing the SCR's is derived from the MVC-IV 120 VAC control system power source. For proper operation, the control system 120 VAC power must come from the same line phase as the T-R set power.



## 5.3 Grounding

### 5.3.1 Logic System Ground

Each control cabinet must have a ground terminal or ground bar bonded to the building earth ground system. All ground connections for the system should tie directly to this single point. It is poor practice to rely on sub panel mounting studs and other bolted structural parts for ground connections.

The ground connections for the MVC-IV system at **INTERFACE** board connector *J1-terminals 3 and 4*, *J4-terminal 12*, and *J5-terminal 4* must each be connected directly to the cabinet grounding terminal by three individual wire runs using AWG 14 wire. *J1-terminals 3 and 4* may be connected together at the **INTERFACE** board and use a single wire run. Do not daisy chain the other terminals together.

### 5.3.2 T-R Set Ground

For proper control operation, the positive ground leg of the T-R bridge must be grounded only through the **INTERFACE** PCB circuit connection at *J6-terminal 1*. Any other ground paths will seriously diminish the accuracy of secondary current metering. A standard surge arrester must be connected between the T-R bridge positive terminal and local earth ground at the T-R set.

### 5.3.3 Current Sensing Transformer

It is common for the primary current sensing transformer in existing installations to be ground referenced. One of the terminals is often grounded either directly or through a connected device such as a meter. **Both terminals of the primary current sensing transformer must be isolated from ground for the MVC-IV to function properly.**

## 5.4 Feedback Signal Wiring

### 5.4.1 Primary Current Feedback

Primary Current feedback originates as a current signal from a low impedance Current Transformer. A twisted pair cable will provide a noise free signal to the MVC-IV **INTERFACE** board. Shielding is not necessary. If the existing twisted pair cable has a

shield, terminate the shield at the **INTERFACE** board at *J5-terminal 3*. All other parts of the shield must be insulated from ground.

### 5.4.2 Primary Voltage Feedback

Primary Voltage feedback signal, although theoretically sourced across the T-R set primary, usually is supplied by the power cable to the T-R and a single feedback wire. From the point where these two wires come together (usually in the control cabinet) use a twisted pair, unshielded cable to connect to the **INTERFACE** board.

### 5.4.3 Secondary Current Feedback

Secondary Current feedback wiring will typically require reworking existing metering circuitry. The ideal installation uses a shielded twisted pair cable for the T-R set secondary current feedback signal to provide the cleanest possible signals.

Secondary Current is measured directly as current flow through the **INTERFACE** board. Any circuitry that allows current to flow to ground without first flowing through the **INTERFACE** board will introduce errors in the control's readings. Typically there is a grounding resistor or network in the low voltage junction box that must be removed leaving only a surge arrester to ground.

Installations that require retaining existing analog meters may require some planning. Analog meters often have filtering and signal division (calibration) circuits that often have components and ground paths in both the T-R set low voltage junction box and the control cabinet. In that case, all circuitry must be moved from the low voltage junction box to the control cabinet, and all ground paths combined into one circuit that connects to ground only through the **INTERFACE** board Secondary Current input at *J6-terminal 1*. The signal return line back to T-R set ground in the low voltage





# MVC IV VOLTAGE CONTROL MANUAL

NEUNDORFER PRECIPITATOR KNOWLEDGE



junction box connects to *J6-terminal 2*. The shield if any connects to *J6-terminal 3*.

## 5.4.4 KV Feedback Wiring

KV feedback wiring will usually require reworking existing metering circuitry. Since KV feedback signals originate from a high impedance source, the ideal installation uses a dedicated shielded twisted pair cable for each bushing to implement a **balanced** feedback circuit, providing the cleanest possible signals.

KV is measured as a sub-milliamp current. Any circuitry that allows current to flow directly to ground without first flowing through the **INTERFACE** board will introduce errors in the control's readings. Impedance differences between the KV signal and return wires degrades common mode noise rejection.

Typically there is a grounding resistor or network in the low voltage junction box that must be replaced by an appropriate surge protector.

Installations that require retaining existing analog meters require additional planning. Analog meters typically have filtering and signal division (calibration) circuits that are split between the T-R set low voltage junction box and the control cabinet and have multiple ground paths. In that case, all circuitry must be moved from the low voltage junction box to the control cabinet, and all ground paths combined into one circuit for each monitored bushing that connects to ground only through the respective **INTERFACE** board KV input.

There are two possible wiring methods for KV feedback. In either case, all circuitry and ground paths in the low voltage junction box must be removed leaving only surge arrestors to ground.

**Balanced** feedback wiring provides the best signal fidelity but requires a dedicated twisted pair cable. **Balanced** feedback may be necessary for waveform analysis and may improve performance of the enhanced spark detection algorithms and the Back Corona Detection and Control software.

For **balanced** feedback wiring, all circuitry including any surge arrestors at the T-R set must be removed and replaced by a Neundorfer *KV Signal Feedback Surge Suppression Module*. This module provides the required surge arrestors that are compatible with the **INTERFACE** board KV input circuit.

**Unbalanced** KV feedback wiring is used when existing feedback wiring must be reused, and there is not a dedicated twisted pair of wires for KV. This is common in retrofits where there is a single milliamp signal wire, a single KV signal wire and a shared return wire. **Unbalanced** KV feedback may reuse existing surge protectors if they have at least 5 megohms resistance to ground.

**Unbalanced** KV feedback wiring often requires filtering the signal at the **LOGIC** board to remove electrical noise. The loss of fidelity still allows accurate average DC KV readings, but removes signal waveform information used for enhanced features mentioned above. See *figure 8, JP71 and JP81 (items 15 and 16)*.

The generic system drawings depict the ideal wiring configuration with **balanced** KV feedback wiring. We realize that in some installations it may not be practical to provide the ideal wiring. *Drawing 8-01-0223, sheet 1* shows the two acceptable wiring methods for the KV feedback signals. *Table 3* lists the **INTERFACE** board terminal jumpers required to configure the desired type of KV feedback circuit.

KVa Jumpers	Balanced KVa	Unbalanced KVa
J6-9 to J6-11	In	Out
J6-10 to J6-12	In	Out
J6-10 to J6-11	Out	In
KVb Jumpers	Balanced KVb	Unbalanced KVb
J5-9 to J5-11	In	Out
J5-10 to J5-12	In	Out
J5-10 to J5-11	Out	In

**Table 3 - KV Circuit Configuration Jumpers**



Neundorfer *KV Signal Feedback Surge Suppression* circuit boards (*assembly number 82200-104*) are supplied with each MVC-IV for each specified high voltage bushing. For **balanced** KV feedback wiring, the circuit board must be used **in place of** the standard surge suppressor or “lightning arrestor” normally located in the voltage divider or T-R set low voltage junction box. It mounts on the existing surge suppressor mounting block, and provides surge suppression and components to implement both the **balanced** and **unbalanced** KV feedback circuits. **Unbalanced** KV feedback wiring may reuse existing surge protectors if they have at least 5 megohms resistance to ground.

Drawing *82200-104* shows the *assembly number 82200-104* board layout, schematic and connections for the two feedback wiring configurations. The KV feedback signal connects to TB-1. For **balanced** configuration, there must be a dedicated signal return line, and it connects to TB-2. For **unbalanced** configuration, the signal return line, if one is present, connects to TB-3. If using an earlier assembly, *82200-016 rev B*, all jumpers are removed for either configuration.

Ensure that terminal TB-3 has continuity to ground either through the mounting block or by installing a wire directly from TB-3 to local earth ground.

Part number *82200-104* boards are usually not required with Neundorfer voltage dividers as the voltage dividers typically include the KV Signal Feedback Surge Suppression circuitry. Refer to the particular voltage divider documentation. **Balanced** type 2 and **unbalanced** type 4 are the only configurations used with MVC-IV.

For voltage divider, assembly number *84700-250*, remove all four jumpers. The KV feedback signal connects to TB1-pin 1. For **balanced** configuration with a dedicated twisted pair cable, the signal return line connects to TB1-pin 2. For **unbalanced** configuration, the signal return line, if one is present, connects to TB1-pin 3.

Ensure that terminal TB1-pin 3 has continuity to ground by installing a wire directly from TB1-pin 3 to local earth ground.

## 5.5 SCR Gate Wiring

Correct SCR Gate wiring materials and methods are critical to proper control operation. Use a tightly twisted pair of unshielded wires rated for 600 VAC operation, no more than 3 feet long, and routed well away from the MVC-IV circuit boards. Do not use shielded cables for the SCR gate signal. Do not bundle SCR gate signal cables with T-R feedback wiring. Failure to follow the prescribed wiring requirement can cause erratic control operation, unexplained random shutdowns and processor error codes indicative of electrical noise interference.

## 5.6 Complete Cabinet or Pre-Wired Back Panel Installation

The complete cabinet and pre-wired back panel final assemblies are fully tested at the factory. For these, the user needs only to connect the main power feed, T-R power, T-R feedback signals and any additional **alarm** or **Permissive** and control wiring desired. Neundorfer supplies as built system schematics, wiring diagrams and equipment layout drawings with MVC-IV complete cabinet and pre-wired back panel configurations.

*Drawing 8-01-0224* is a basic wiring diagram identifying all connections needed for a typical installation. For detailed information on optional connections, see generic system schematic *drawing 8-01-0223*, wiring diagram *drawing 8-01-0224* and the **INTERFACE** board connections *drawing 8-01-0229*. In some cases custom as installed drawings are also supplied. Refer to the drawing lists in *appendix D*.





## 5.7 Major Assembly Subsystems Retrofit Installation

The MVC-IV can be purchased as major assembly subsystems for customer retrofit installation. The subsystems are:

- **FACE PANEL** and **DISPLAY** board assembly (optional)
- DIN rail assembly with stacked main **LOGIC** board and customer **INTERFACE** board.

The **LOGIC** board plugs directly into the **INTERFACE** board and the **DISPLAY** assembly connects to the **LOGIC** board using a standard RJ-45 network cable. The **LOGIC / INTERFACE** assembly is contained on a DIN rail along with the optional **CMR**. The **DISPLAY** assembly surface mounts to the cabinet, requiring only a small hole for pass through of the interconnecting cable.

In some cases, controls may be supplied without a **DISPLAY** panel. Each control will instead have a sealed RJ-45 receptacle for mounting in the door to enable connecting a portable **DISPLAY** panel.

Since every control is custom engineered to the particular installation, additional major components, such as SCR stack or contactor, may be supplied as part of a retrofit control.

Remove all equipment not being reused from the control cabinet. Select the mounting site for all supplied subsystems and prepare the required back panel and door mounting holes and cutouts.

### The Face Panel and Display Board

Mount the **FACE PANEL** and **DISPLAY** assembly, if purchased, to the cabinet door in the desired location using the provided hardware. Use the provided template, *drawings 8-01-0232* to make the required door cutout and mounting holes.

### The Interface and Logic Board

Mount the DIN rail assembly containing the **INTERFACE** and **LOGIC** boards in a position central to the existing wiring and within a two foot wire run to the SCR assembly. Mount all other supplied equipment. Make all customer connections to the **INTERFACE** board and to any other supplied equipment. Dress and secure all cabling so that it will not be damaged by hot components or door movement.

*Drawing 8-01-0224* is a basic wiring diagram identifying all connections needed for a typical installation. For detailed information on optional connections, see generic system schematic *drawing 8-01-0223*, wiring diagram *drawing 8-01-0224* and the **INTERFACE** board connections *drawing 8-01-0229*. In some cases custom as installed drawings are also supplied. Refer to the drawing lists in *appendix D*.

### 5.8 Continuity Test

Before applying power to the completed installation, use a volt-ohmmeter to verify continuity of all connections.



# MVC IV VOLTAGE CONTROL MANUAL

NEUNDORFER PRECIPITATOR KNOWLEDGE



This page intentionally blank.



# MVC IV VOLTAGE CONTROL MANUAL

NEUNDORFER PRECIPITATOR KNOWLEDGE



## 6.0 OPERATOR CONTROLS

### 6.1 MVC-IV Readouts & Indicators

The MVC-IV **DISPLAY** panel shown in *figure 1* has both dedicated and multi-function digital readouts along with 29 status indicators. The digital readouts show setpoint data when the T-R set is off and normally show real time operating values when the T-R set is energized. The status indicators flash briefly when an operating limit has been reached.

A rapidly blinking status indicator means that the corresponding digital readout is showing the setpoint limit. The limit can be adjusted using the **Up**, **Down** and **Set** keys if the **DISPLAY** panel security access code has been satisfied (Access LED illuminated). See *section 9* for how to change setpoints.

If the T-R trips off, the entire display flashes to draw attention. Pressing **Stop** and then **Hold** will stop the display from flashing making it easier to read the display and determine the cause of the trip.

The following digital readouts and status indicators are located on the MVC-IV **DISPLAY** panel. Refer to *figure 1* for item number identification.

<u>Item</u>	<u>Description</u>
1	<b>Primary Amps DIGITAL READOUT</b> Displays primary T-R set operating current (or current limit) in RMS amps.
2	<b>Primary Amps - Limit LED</b> Flashes when Primary Current Limit has been reached or remains lit if exceeded. Blinks rapidly when digital readout ( <i>item 1</i> ) is displaying T-R Primary Current Limit.
3	<b>Primary Amps - Unbalance LED</b> Flashes when primary current flowing through the T-R is not equal on opposing half cycles of the line.

<u>Item</u>	<u>Description</u>
4	<b>Primary Volts DIGITAL READOUT</b> Displays primary T-R set operating voltage (or voltage limits) in RMS Volts.
5	<b>Primary Volts - Limit LED</b> Flashes when Primary Voltage Limit has been reached or remains lit if exceeded. Blinks rapidly when digital readout ( <i>item 4</i> ) is displaying T-R Primary Over Voltage Limit.
6	<b>Primary Volts - Low LED</b> Flashes when T-R primary voltage has dropped below the preset limit. Blinks rapidly when digital readout ( <i>item 4</i> ) is displaying T-R Primary Under Voltage Limit.
7	<b>Secondary Amps DIGITAL READOUT</b> Displays secondary T-R set operating current (or current limit or reduced power rapping limit) in average DC amps.
8	<b>Secondary Amps - Limit LED</b> Flashes when Secondary Current Limit has been reached or remains lit if exceeded. Blinks rapidly when digital readout ( <i>item 7</i> ) is displaying T-R Secondary Current Limit.
9	<b>Secondary Amps - Rap Limit LED</b> Flashes when Reduced Power Rapping (RPR) logical condition is asserted and Secondary Current Limit has reached the RPR value. It remains lit during Power Off Rapping (POR). Blinks rapidly when digital readout ( <i>item 7</i> ) is displaying T-R Reduced Power Rapping Secondary Current Limit.



# MVC IV VOLTAGE CONTROL MANUAL

NEUNDORFER PRECIPITATOR KNOWLEDGE



## 6.1 MVC-IV Readouts & Indicators (con't)

<u>Item</u>	<u>Description</u>	<u>Item</u>	<u>Description</u>
10	<b>Secondary KV DIGITAL READOUT</b> Displays T-R set secondary operating voltage (or limits) in average DC kilovolts.	16	<b>Response - Setback LED</b> Flashes when maximum Setback is reached (SCR Conduction Angle is at minimum). Blinks rapidly when digital readout ( <i>item 14</i> ) is displaying Post Spark Setback factor setpoint.
11	<b>Secondary KV - A &amp; B LED's</b> Identifies the KV bushing displayed in the KV digital readout and flashes along with the <b>Limit</b> or <b>Low</b> LED's to indicate the out of limit bushing(s). Blinks rapidly along with <i>item 13</i> to identify the target KV bushing.	17	<b>Response - Mode LED</b> Blinks rapidly when digital readout ( <i>item 14</i> ) is displaying Spark Response Mode.
12	<b>Secondary KV - Limit LED</b> Flashes when Secondary Voltage Limit has been reached or remains lit if voltage limit has been exceeded. Blinks rapidly when digital readout ( <i>item 10</i> ) is displaying T-R Secondary KV over voltage Limit.	18	<b>Response - Back Corona LED</b> Blinks rapidly when digital readout ( <i>item 14</i> ) is displaying the Back Corona Setup Code. A code of zero (" <b>OFF</b> ") disables the Back Corona Control program, while a setting of 1 (" <b>on</b> ") enables it. Illuminates when Back Corona software is enabled. Blinks off momentarily to indicate MVC-IV is making a corrective response to limiting T-R operation below back corona onset.
13	<b>Secondary KV - Low LED</b> Flashes when T-R secondary voltage has dropped below the preset limit. Blinks rapidly when digital readout ( <i>item 10</i> ) is displaying T-R Secondary KV under voltage Limit.	19	<b>Response - IE LED</b> Blinks rapidly when digital readout ( <i>item 14</i> ) is displaying the IE ratio. A setting of 0.00 (" <b>OFF</b> ") disables IE while settings of X.YY enables IE with X half cycles of <b>ON</b> time and YY half cycles of <b>OFF</b> time. To prevent T-R damage, the control will not allow setting odd number of <b>OFF</b> half cycles.
14	<b>Response DIGITAL READOUT</b> When T-R is energized, displays number of precipitator sparks occurring during the last minute. Also shows Baseline Spark Rate, Setback factor, Spark Response Mode, Back Corona Control, IE, and AutoMax feature settings when these parameters are being adjusted. See <i>sections 9.9-9.14</i> .	20	<b>Response - AutoMax LED</b> Blinks rapidly when digital readout ( <i>item 14</i> ) is displaying the AutoMax Setup Code. A code of zero (" <b>OFF</b> ") disables the AutoMax program. Illuminates when AutoMax software is active. Flashes slowly when the AutoMax program is controlling T-R operation.
15	<b>Response - Spark LED</b> Flashes when a spark has been detected. Blinks rapidly when digital readout ( <i>item 14</i> ) is displaying Baseline Spark Rate setpoint.		



# MVC IV VOLTAGE CONTROL MANUAL

NEUNDORFER PRECIPITATOR KNOWLEDGE



## 6.1 MVC-IV Readouts & Indicators (con't)

<u>Item</u>	<u>Description</u>	<u>Item</u>	<u>Description</u>
21	<b>Auxiliary Functions DIGITAL READOUT</b> Displays the parameter indicated by items 22-25.	26	<b>Auxiliary Func. - Access LED</b> Indicates that keypad control of setpoints is enabled. See MVC-IV <b>DISPLAY</b> Panel User Manual <i>section 13</i> for instructions to enable and disable keypad access to setpoints.
22	<b>Auxiliary Func. - KW LED</b> Lights when digital readout ( <i>item 21</i> ) is displaying T-R set Kilowatts. Software Option Code offers selection of primary or secondary KW. See <i>section 8.1</i> .	27	<b>Status - T-R On LED</b> Indicates the T-R set is energized.
23	<b>Auxiliary Func. - Cond. Angle LED</b> Lights steady when digital readout ( <i>item 21</i> ) is displaying SCR Conduction Angle. Flashes slowly when SCR Conduction Angle is at the setpoint limit. Blinks rapidly when digital readout ( <i>item 21</i> ) is displaying the SCR Conduction Angle setpoint limit.	28	<b>Status - T-R Off LED</b> Indicates the T-R set is not energized.
24	<b>Auxiliary Func. - Temperature LED</b> Lights steady when digital readout ( <i>item 21</i> ) is displaying the temperature at the main <b>LOGIC</b> board. Flashes slowly when Temperature is above the alarm limit. Blinks rapidly when readout ( <i>item 21</i> ) is displaying the temperature setpoint limit.	29	<b>Status - T-R Opt. Limit LED</b> Indicates T-R set operation is being limited below sparking or nameplate limits by the POS optimization program.
25	<b>Auxiliary Func. - Data Link LED</b> Lights steady when digital readout ( <i>item 21</i> ) is displaying the Unit Number Address of this controller or the POS Access Status. Flashes briefly to acknowledge receipt of a data link message. Blinks rapidly when digital readout ( <i>item 21</i> ) is displaying the Unit Number Address or the POS Access setpoints. POS Access Status has three settings, " <b>OFF</b> ", " <b>on</b> " and " <b>EnA</b> ". " <b>OFF</b> " disables POS access. The MVC-IV will not reply to any POS messages. " <b>on</b> " enables POS read only access. " <b>EnA</b> " gives POS full control over MVC-IV operation and setpoints.	30	<b>Status - Internal Trip LED</b> Indicates the T-R set has been de-energized by an internally detected uncorrectable error condition such as under voltage. Other <b>DISPLAY</b> panel status indicators will indicate the cause of the trip.
		31	<b>Status - External Trip LED</b> Indicates the T-R set was de-energized by an external trip condition. Possible causes are the <b>External Trip</b> logical input was asserted, loss of the <b>Permissive</b> signal, or the optional <b>CMR</b> detected an over current condition. Since there is a time lag between the external trip event shutting down T-R power and notification to the <b>LOGIC</b> board processor, the display values will be lower than actual operating values at the trip instant.



# MVC IV VOLTAGE CONTROL MANUAL

NEUNDORFER PRECIPITATOR KNOWLEDGE



## 6.1 MVC-IV Readouts & Indicators (con't)

<u>Item</u>	<u>Description</u>	<u>Item</u>	<u>Description</u>
32	<b>Status - Permissive LED</b> Indicates the <b>Permissive</b> logical signal is asserted. Flashes to indicate attempt to energize T-R with permissive conditions not satisfied.	34	<b>Status - Remote Stop LED</b> Indicates the <b>Remote Stop</b> logical condition is asserted. The logical condition is a user definable combination of one or more opto coupler inputs.
33	<b>Status - Remote Start LED</b> Indicates the <b>Remote Start</b> logical condition is asserted. The logical condition is a user definable combination of one or more opto coupler inputs.		

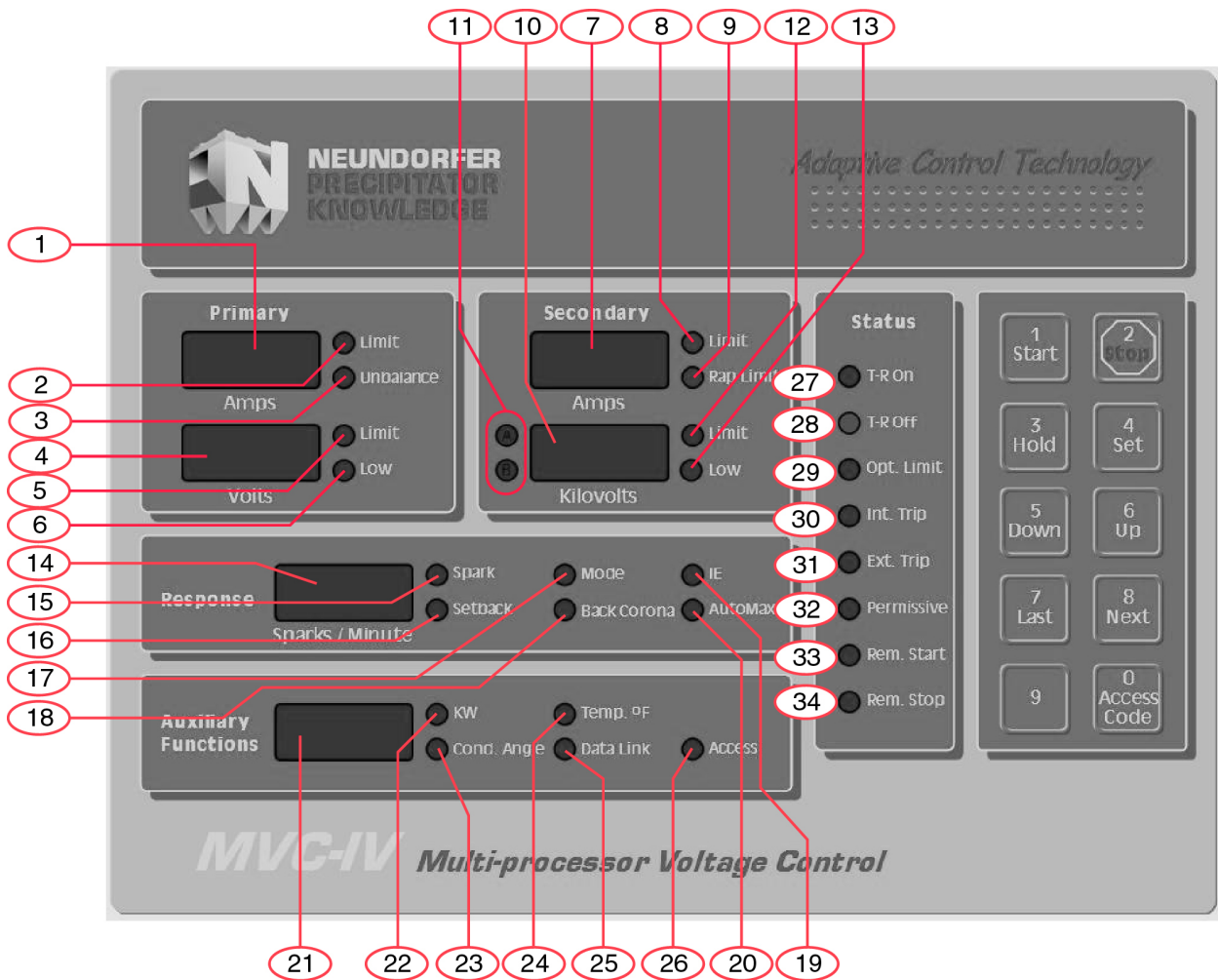

Figure 1 - MVC-IV Display Panel Item Identification





# MVC IV VOLTAGE CONTROL MANUAL

NEUNDORFER PRECIPITATOR KNOWLEDGE



## 6.2 Keypad (figure 2)

The MVC-IV **DISPLAY** panel has a ten position keypad to access and adjust all setpoint parameters. Included are T-R **Start** and **Stop** keys and keys for programming and using the Security Access code.

The **Last** and **Next** keys act as cursor motion control keys to move through the MVC-IV parameters. A parameter selected for adjustment is indicated by a fast blinking indicator light and can

be adjusted **Up** or **Down** with the respective key. To lock a new setting into memory press **Set**.

The Conduction Angle Limit, Temperature Alarm Limit and Data Link are special cases that require first pressing the **Set** key to change the display from the operating value to the setpoint value then pressing the **Set** key again after adjustment to lock in the new value.

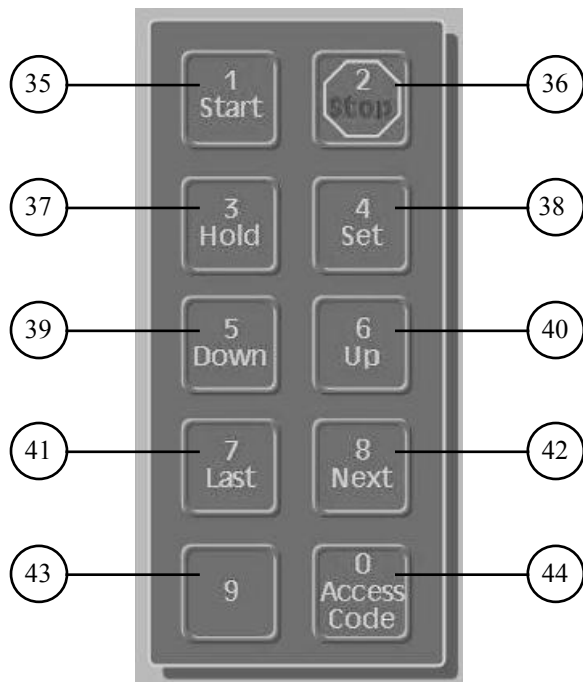

Figure 2 - Keypad

Item	Description
35	<b>Start Key</b> - Always enabled to provide T-R Start command if the control is not tripped and there are no asserted Stop commands.
36	<b>Stop Key</b> - Always enabled to provide T-R Stop command. Overrides any pending Start commands. Also resets trip condition

Item	Description
37	<b>Hold Key</b> - Updates then freezes the digital readouts and indicators but does not affect the control's operation. Press the <b>Hold</b> key again to unfreeze the <b>DISPLAY</b> .
38	<b>Set Key</b> - Locks in the new setpoint or limit value. When the <b>Set</b> key is pressed, if the selected parameter has changed, the cursor will move to the next position to confirm entry of the new setpoint.
39	<b>Down Key</b> - Decreases selected setpoint adjustment. Hold for auto-repeat.
40	<b>Up Key</b> - Increases selected setpoint adjustment. Hold for auto-repeat.
41	<b>Last Key</b> - Permits reverse sequential selection of the parameter for display and adjustment in the various digital readouts.
42	<b>Next Key</b> - Permits forward sequential selection of the parameter for display and adjustment in the various digital readouts.
43	<b>"9" Key</b> - Numeric "9" entry for Security Access Code.
44	<b>Access Code Key</b> - Multi-function key for activating security access entry mode, disabling security access, and accessing security access re-programming mode. See MVC-IV <b>DISPLAY</b> User Manual ( <i>sec. 13</i> ) for more details.



# MVC IV VOLTAGE CONTROL MANUAL

NEUNDORFER PRECIPITATOR KNOWLEDGE



## 6.3 T-R On Switch

The **T-R On** switch, shown schematically in *drawings 8-01-0223* and *8-01-0224*, is usually provided with the MVC-IV, but may be a reused customer device. It is a two position single pole switch combined with a 120 VAC pilot light. The switch contacts are wired into the contactor coil circuit to provide fail safe shut off. Closing the switch provides a Run Request to the control system, which will energize the T-R set if all other run requirements are met. The pilot light is illuminated when the T-R set is energized. Opening the **T-R On** switch overrides the data link commands and **Remote Start** commands, shutting down the T-R set.

The **T-R On** switch is optional, in that the control may be operated without it by connecting a jumper on J4 in place of the contacts. The keypad **Start** and **Stop** keys can be used to turn the T-R set on and off. Neundorfer recommends using the **T-R On** switch as it provides a positive means to break the contactor coil circuit for fail safe shutdown.





## 7.0 MVC-IV MODES

With control power applied the MVC-IV can be in one of four possible modes or conditions:

- **STANDBY**
- **TRIPPED**
- **OPERATING**
- **SYSTEM SETUP**
- **FACTORY CALIBRATION**

### 7.1 Standby Mode

**Standby Mode** is the normal mode when the T-R set is not energized and the control is not tripped. The indicator light in the optional **T-R On** switch will be off, the **T-R On** front panel indicator will be off, and the **T-R Off** front panel indicator will be on.

### 7.2 Tripped

**Tripped** condition results from an out of limit condition that the MVC-IV cannot correct or from external inputs. When a trip occurs, the entire **DISPLAY** is frozen at the moment of the trip, the **T-R On** front panel indicator turns off, the **T-R Off** front panel indicator turns on and the appropriate **Internal** or **External Trip** LED is illuminated.

The **DISPLAY** can be unfrozen by pressing the **Hold** key.

Opening the **T-R On** switch or pressing the **Stop** key will change the control mode back to Standby Mode and deactivate the Trip Alarm relay. This can also be done using the **Remote Stop** or **Ack Alarm** contact inputs or via data link commands.

### 7.3 Operating (Run) Mode

With the MVC-IV in the **Operating** or **Run Mode** the T-R set is energized and the MVC-IV is monitoring and controlling power delivery to the T-R set and the bus section. The front panel **T-R On** switch and the **Permissive** inputs must be asserted to enter the Run Mode. With these circuits asserted, the MVC-IV can be stopped, reset from trips and started using the keypad **Start** and **Stop** keys, the **Remote Start**, **Stop** and **Ack Alarm** contact inputs or via data link commands. Opening the front panel **T-R On** switch or de-asserting the **Permissive** logical input will always override all **Start** commands.

### 7.4 System Setup Mode

**System Setup Mode** is a special mode used to select certain software options, configure several opto coupler inputs to the system and enter T-R transducer parameters size.

MVC-IV System Setup Mode may be accessed by a **REMOTE NETWORK DISPLAY** or a **DIRECT CONNECTED DISPLAY**. See [section 8](#) for complete details on setting software and hardware options.

Note that certain of the System Setup Mode parameters affect the range of allowed normal operation setpoints; specifically Primary Current Limit, Secondary Current Limit and KV Limit.

Exit or abort MVC-IV System Setup Mode programming at any time by pressing and releasing the **Stop** key.

Changes already save by pressing the **Set** key will be retained. Those that have not been saved will be lost.



# MVC IV VOLTAGE CONTROL MANUAL

NEUNDORFER PRECIPITATOR KNOWLEDGE



## 7.5 Factory Calibration Mode

Factory Calibration Mode is for factory use only. No adjustments should be made by the end user.

MVC-IV Factory Calibration Mode may be accessed by a network REMOTE DISPLAY or a DIRECT CONNECTED DISPLAY.

### 7.5.1 To Enter Calibration Mode:



### 7.5.2 To Exit Control Calibration Mode:

- Exit or abort MVC-IV Control Calibration mode programming at any time by pressing and releasing the **Stop** key.
- Changes already save by pressing the **Set** key will be retained. Those that have not been saved will be lost.

Readout	Item
Pri Amps	Pri. Current cal, nominal 100 (range 50-150)
Pri Volts	Pri Volt cal, nominal 100 (range 50-150)
Sec Amps	Sec. Current cal, nominal 100 (range 50-150)
KVa	KVa cal, nominal 100 (range 50-150)
KVb	KVb cal, nominal 100 (range 50-150)
SPM	Spark sensitivity, nominal 100 (range 0-200)

Each parameter may be changed using the **Down** and **Up** keys. For the first five parameters each count in the setting provides a gain change of 0.40%. The spark sensitivity has no meaningful calibration value associated with it. When the values are correct, press the **Set** key to save the new setting. The **Set** key saves all the parameters, so it need only be pressed once after all the desired changes have been made.



# MVC IV VOLTAGE CONTROL MANUAL

NEUNDORFER PRECIPITATOR KNOWLEDGE



## 8.0 SOFTWARE CONFIGURATION

The MVC-IV feature user configurable software options to customize the MVC-IV to the particular installation. These settings are made at the time of installation and are not usually changed again. They have been made less accessible than the operator set point adjustments. When possible, the controls are shipped with these parameters pre-configured. The configurable parameters in order of access are:

- Software Option Code
- Primary Current CT rating
- Secondary current range
- KV Bushing “A” divider megohms
- KV Bushing “B” divider megohms
- Opto Coupler Input assignment

Changing any of these values requires entering the System Setup Mode with the control off line.

To enter System Setup Mode:

1. Stop the MVC-IV with the front panel **T-R On** switch or by pressing the **Stop** key.
2. Enable security access.
3. Press and **hold** the **Stop** key.
4. Sequentially pressing and releasing the **Set**, **Up** and **Next** keys.
5. Release the **Stop** key. System Setup Mode initializes to the Firmware ID and Software Options Code.
6. Use the **Next** and **Last** keys to select the desired parameter which will appear in its assigned readout as indicated in *table 4*.
7. Use the **Up** or **Down** keys to change the selected parameter to the desired value.
8. When settings are satisfactory, enter new configuration codes into memory by pressing the **Set** key which saves all parameters. The Auxiliary Readout briefly changes to "**PPP**" to indicate the new values are being programmed into memory. Pressing the **Set** key also calculates and saves to EERPOM a new FLASH checksum for start up memory check.
9. Press and release the **Stop** key to exit System Setup Mode.

Access Order	Parameter	Readout	Value Ranges
1	Logic Board Firmware ID	Pri & Sec Amps	<b>L2.1d28</b> or <b>-2.1d28</b> (Typical value)
1	Software Option Code	Response = <b>5.0.C.</b> Aux. = Code	<b>5.0.C.</b> <b>0-31</b> (see table 5)
2	Primary Current CT rating Requires (XXX:5) CT	Primary Amps	<b>50-995</b> (Amps) or 1.00 - 1.20 (KAmps) to produce 5 Amps output
3	Secondary current range	Secondary Current	Max <b>3.20</b> A.
4	KV Bushing “A” divider megs	Kilovolts + “A”	<b>40-400</b> meg ohms
5	KV Bushing “B” divider megs	Kilovolts + “B”	<b>40-400</b> meg ohms
6	Opto Coupler “AND” code	Response = <b>And</b> Aux. = Code	<b>And</b> <b>3-127</b> in steps of 4 (see Table 9)
7	Opto Coupler “Chan 0”	Response = <b>ch0</b> Aux. = 1	Cannot be changed
8	Opto Coupler “Chan 1”	Response = <b>ch1</b> Aux. = 2	Cannot be changed
9-13	Opto Coupler “Chan 2” through “Chan 6” code	Response = <b>ch2-ch6</b> Aux. = Code	<b>ch2-ch6</b> (see Table 10 for values)

Table 4 - Software Configuration Parameters



# MVC IV VOLTAGE CONTROL MANUAL

NEUNDORFER PRECIPITATOR KNOWLEDGE



## 8.1 Selecting Software Options

Enter the System Setup Mode with the control off line as explained in *section 8.0*. The **RESPONSE** readout will show **5.0.C.** indicating Software Option Code and the Software Option numerical code will appear in the **AUXILIARY FUNCTIONS** display. All other displays will be blanked.

*The Software Options Code is the sum of the values for each of the enabled or selected software options.*

For some of the software options, the zero value may select an alternate option.

VALUE	SOFTWARE OPTION
16 = 0 =	<b>POS Port</b> configured for <b>DISPLAY LAN</b> <b>POS Port</b> configured for POS LAN
8 = 0 =	Display secondary KW Display primary KW
4 = 0 =	K3 energizes to trip breaker on T-R runaway K3 de-energizes when T-R is off
2 =	Unbalance condition alarms without tripping control
1 =	Enable AUTO RESTART after power failure with control on. See <i>section 10.1</i> .

**Table 5 - Software Options Coding**

Use the **Up** or **Down** keys to change the Software Options Code to the desired value. Press the **Set** key to save the new code.

## 8.2 Setting T-R Primary CT Size

### CAUTION

**Changing T-R Primary CT Size affects Primary Current metering accuracy, which could allow T-R current to exceed nameplate rating.**

The Primary Current sensing Transformers (CT) is always a XXX : 5 CT. That is, it outputs 5 Amps at the rated XXX amps flowing in the primary circuit.

For CT's rated 150:5 and above, the allowed CT XXX rating is restricted to the range of 1.11 to 4.44 times the primary current limit for the T-R set. Stated another way, Primary Current Limit adjustment is restricted to approximately 22.5% to 90% of the CT primary Amps rating. CT's below 150:5 are assumed to have lower VA ratings and are, therefore restricted to less than 90% of the CT primary Amps rating. See *table 6* for typical CT's and allowed primary current ranges.

Setting a CT rating that results in the present Primary Current limit being outside of the allowed range will cause the control to halt showing a 1.3.4. error code in the Aux Function display and the present Primary Current Limit in the Primary Amps display when the control exits System Setup Mode.

The corrective action is to re-enter System Setup Mode, change the CT value to a setting that will allow the present Primary Current Limit and the desired Primary Current Limit value. Exit to normal control operating mode to set the desired Primary Current Limit. Re-enter System Setup Mode and change the CT setting to the correct value. If there is a large change required in the CT value, it may take several cycles through System Setup Mode to accomplish the desired settings. This possibly cumbersome procedure is used to ensure that the Primary Current Limit is not accidentally set higher than permitted by nameplate rating and to ensure adequate Primary Current Signal for accurate metering.



# MVC IV VOLTAGE CONTROL MANUAL

NEUNDORFER PRECIPITATOR KNOWLEDGE



To adjust Primary CT size, enter the System Setup Mode with the control off line as explained in [section 8.0](#).

Use the **Next** key to display the T-R Primary CT Size in the **T-R PRIMARY AMPS** digital readout. Use the **Up** or **Down** keys to change the T-R Primary CT Size to the desired value. Note that CT ratings of 1000 - 1200 Amps will display as kilo amps. That is 1200 Amps displays as 1.20.

Press the **Set** key to save the new value. The **AUXILIARY** digital display briefly changes to **"PPP"** to indicate the new value is being programmed into memory.

Standard CT's	T-R Pri Current Adjustment Range
50:5	11 - 32
60:5	13 - 38
75:5	16 - 48
80:5	18 - 51
100:5	22 - 64
120:5	27 - 85
125:5	28 - 89
150:5	33 - 135
200:5	45 - 180
250:5	56 - 225
300:5	67 - 270
400:5	90 - 360
500:5	112 - 450
600:5	135 - 540
750:5	168 - 640
800:5	180 - 640
1000:5	225 - 640
1200:5	270 - 640

**Table 6 - T-R Primary Current Range vs. CT**

## 8.3 Setting T-R Secondary Maximum Current Limit

**CAUTION**

**Changing T-R Secondary Maximum Current Limit may allow setting operating current limit above T-R nameplate rating.**

Secondary Maximum Current Limit dictates the highest value that can be set in normal operating mode for secondary current limit. It is recommended that this value be set to T-R nameplate Secondary Average Current rating. This would allow operators to reduce secondary current limit, but not raise it above nameplate.

Enter the System Setup Mode with the control off line as explained in [section 8.0](#).

Use the **Next** key to display the T-R Secondary Maximum Current Limit in the **T-R SECONDARY AMPS** digital readout.

Use the **Up** or **Down** keys to change the T-R Secondary Maximum Current Limit to the desired value.

Press the **Set** key to save the new value. The Auxiliary Readout briefly changes to **"PPP"** to indicate the new value is being programmed into memory.

Exiting System Setup Mode with the Maximum Secondary Current Limit set lower than the present Operating Secondary Current Limit will automatically adjust the Operating Secondary Current Limit down to match the Maximum Secondary Current Limit value.



# MVC IV VOLTAGE CONTROL MANUAL

NEUNDORFER PRECIPITATOR KNOWLEDGE



## 8.4 Setting KV Divider Values

### CAUTION

**Changing KV Divider setting affects KV metering accuracy, which could allow T-R KV to exceed nameplate rating.**

The KV divider tells the control the megohms in the divider(s) so that the control can properly scale the KV metering signal. The MVC-IV can accommodate KV dividers from 40 megohms to 400 megohms. There are individual settings for “A” and “B” bushing inputs.

The lower of the two KV divider values sets the upper limit on operating KV as indicated in *table 7* in order to ensure reasonable signal level and prevent excessive dissipation in the divider.

Enter the System Setup Mode with the control off line as explained in *section 8.0*.

Use the **Next** key to display the T-R KV<sub>a</sub> divider megohms in the **KV** readout with the “A” bushing indicator illuminated.

Use the **Up** or **Down** keys to select the correct value.

Use the **Next** key to display the T-R KV<sub>b</sub> divider megohms in the **KV** readout with the “B” bushing indicator illuminated.

Use the **Up** or **Down** keys to select the correct value. For single bushing T-R sets, set the “B” bushing megohms to match the “A” bushing setting.

Press the **Set** key to save the new values. The Auxiliary Readout briefly changes to “**PPP**” to indicate the new value is being programmed into memory.

Exiting System Setup Mode with the Operating KV Over Limit set higher than allowed by the smaller of the KV divider values will automatically adjust the Operating KV Over Limit down to match the Maximum KV Limit allowed.

Divider Megohms	T-R KV Limit Max
40	50
50	55
60	60
80	70
100	80
120	90
160	105
200	120
400	120

**Table 7 - Max T-R KV Limit vs. Divider**





# MVC IV VOLTAGE CONTROL MANUAL

NEUNDORFER PRECIPITATOR KNOWLEDGE



## 8.5 Configuring Opto Coupler Inputs

MVC-IV has seven opto coupler inputs for 120 V AC or DC digital inputs as listed in *table 8*. Two are permanently configured for **RUN REQUEST** and **PERMISSIVE** signals. The other five may be re-configured to any combination of the seven functions. Additionally if multiple inputs are configured for the same function, the logic may be configured to require ANY of the inputs to be asserted to activate the function (OR function) or require ALL of the inputs to be asserted to activate the function (AND function).

The five configurable opto coupler inputs may be configured for assertion on presence of signal or on absence of signal.

Channel	Connection	Default Function
6	J3-3 & J3-4	Reduced Pwr. Rap
5	J3-11 & J3-12	Ack Alarm
4	J3-5 & J3-6	Remote Start
3	J3-7 & J3-8	Remote Stop
2	J3-9 & J3-10	External Trip
1	Internal	Permissive
0	Internal	Run Request

**Table 8 - Opto Input Channels & Connections**

Opto coupler configuration utilizes the **RESPONSE** and **AUXILIARY FUNCTIONS** readouts.

The **RESPONSE** readout indicates the parameter being configured as: **Rnd**, **ch0**, **ch1**, **ch2**, **ch3**, **ch4**, **ch5** or **ch6** and the configuration is displayed as a numeric code in the **AUXILIARY FUNCTIONS** readout.

*Table 9* lists the available codes for the “AND/OR” function and *Table 10* lists the possible Functional and Polarity Assignment codes for each opto coupler input channel.

### 8.5.1 Setting the “AND” function

Enter the System Setup Mode with the control off line as explained in *section 8.0*.

Use the **Next** key to access the Opto Coupler “**Rnd**” function in the **RESPONSE** readout with its numeric code in the **AUXILIARY FUNCTIONS** display.

The “**Rnd**” code is a bit-wise code with bits 0 - 6 assigned to the seven opto coupler functions (not the physical opto channels) as listed in *Table 9*. If a bit is set then all opto channels assigned to that function must be asserted for the logical function to be true. If the bit is clear any opto channel assigned to that function will activate the function. Add up the values for the desired configuration and enter that total value as the “**Rnd**” value.

Bits 0 and 1 are set at all times, forcing an “**Rnd**” function for all **RUN REQUEST** and **PERMISSIVE** inputs. All other bits may be set as desired.

Press the **Set** key to save the new value. The Auxiliary Readout briefly changes to “**PPP**” to indicate the new value is being programmed into memory.

VALUE	Opto “And” codes
64 =	<b>AND</b> all REDUCED POWER RAPPING inputs
0 =	<b>OR</b> all REDUCED POWER RAPPING inputs
32 =	<b>AND</b> all ACK ALARM inputs
0 =	<b>OR</b> all ACK ALARM inputs
16 =	<b>AND</b> all REMOTE START inputs
0 =	<b>OR</b> all REMOTE START inputs
8 =	<b>AND</b> all REMOTE STOP inputs
0 =	<b>OR</b> all REMOTE STOP inputs
4 =	<b>AND</b> all EXTERNAL TRIP inputs
0 =	<b>OR</b> all EXTERNAL TRIP inputs
2 =	<b>AND</b> all PERMISSIVE inputs
0 =	Not allowed
1 =	<b>AND</b> all RUN REQUEST inputs.
0 =	Not allowed

**Table 9 - Opto Inputs AND/OR Encoding**





# MVC IV VOLTAGE CONTROL MANUAL

NEUNDORFER PRECIPITATOR KNOWLEDGE



## 8.5.2 Setting the Opto Input function

Enter the System Setup Mode with the control off line as explained in *section 8.0*.

Use the **Next** key to access the desired Opto Coupler input channel. The **RESPONSE** readout will indicate the channel number as **ch0** through **ch6** with its numeric functional assignment code in the **AUXILIARY FUNCTIONS** display. **ch0** and **ch1** are permanently assigned to RUN REQUEST and PERMISSIVE respectively configured for active input true condition and cannot be changed. **ch2** through **ch6** can be reassigned as desired to any of the functions except Run Request.

ACK ALARM can be combined with REMOTE START or REMOTE STOP so that REMOTE START or REMOTE STOP can also cancel the TRIP ALARM output. *Table 10* shows the available code selections.

Press the **Set** key to save the new values. The Auxiliary Readout briefly changes to "**PPP**" to indicate all changed values are being programmed into memory.

VALUE	True	Opto Function & Polarity Assignment Codes
192 =	OFF	REDUCED POWER RAPPING
176 =	OFF	ACK ALARM and REMOTE START
168 =	OFF	ACK ALARM and REMOTE STOP
160 =	OFF	ACK ALARM
144 =	OFF	REMOTE START
136 =	OFF	REMOTE STOP
132 =	OFF	EXTERNAL TRIP
130 =	OFF	PERMISSIVE
64 =	ON	REDUCED POWER RAPPING
48 =	ON	ACK ALARM and REMOTE START
40 =	ON	ACK ALARM and REMOTE STOP
32 =	ON	ACK ALARM
16 =	ON	REMOTE START
8 =	ON	REMOTE STOP
4 =	ON	EXTERNAL TRIP
2 =	ON	PERMISSIVE
1 =	ON	RUN REQUEST

Table 10 - Opto Inputs Function Encoding



## 9.0 ADJUSTING LIMITS AND SETPOINTS

**BEFORE** setting any limits, the proper Primary CT size, T-R Secondary maximum current limit, and KV divider values must be set. If these settings are not correct, the current and KV readings will be incorrect. See *sections 8.2 - 8.4* for the correct settings and procedure.

When the MVC-IV is in the Standby Mode the principle adjustable limits and setpoints are displayed: Primary Over Current, Primary Under Voltage, Secondary Over Current, Secondary Over Voltage and Baseline Spark Rate. The auxiliary setpoints and limits can be accessed using the keypad. All limits and setpoints may be adjusted while in Standby or Operating Modes.

Access to the setpoint adjustments is controlled by the **DISPLAY** panel (*sec 13*) or **POS Security Access** feature. Refer to the **DISPLAY** panel or POS manuals for operation of the **Security Access** feature. Access must be enabled to change any of the setpoints.

When access is not enabled, setpoint values can be viewed and certain ones can be temporarily changed from the **DISPLAY** panel keypad. No new values can be written into nonvolatile memory and any temporary values will automatically revert back to their normal settings after *five minutes* without keypad activity.

With **DISPLAY** panel access enabled, the limits and operating setpoints for the MVC-IV are entered and set using five of the front panel keypad on the right side of the **DISPLAY** panel (*figure 2, items 38 - 42*).

The **Last** and **Next** keys move the cursor (*readout parameter indicator*) sequentially through the displayable parameters and setpoints associated with each digital readout. The top five digital readouts each display one real time monitored parameter and provide setting of one or more operational limits or setpoints. A rapidly blinking LED indicates that the displayed number is the setpoint, not the real time monitored value and the

setpoint can be adjusted using the **Down** or **Up** keys.

After adjusting the value, enter it into non volatile memory by pushing the **Set** key. If the value has changed, the cursor will automatically move to the next parameter in the direction last moved to acknowledge the new value has been saved.

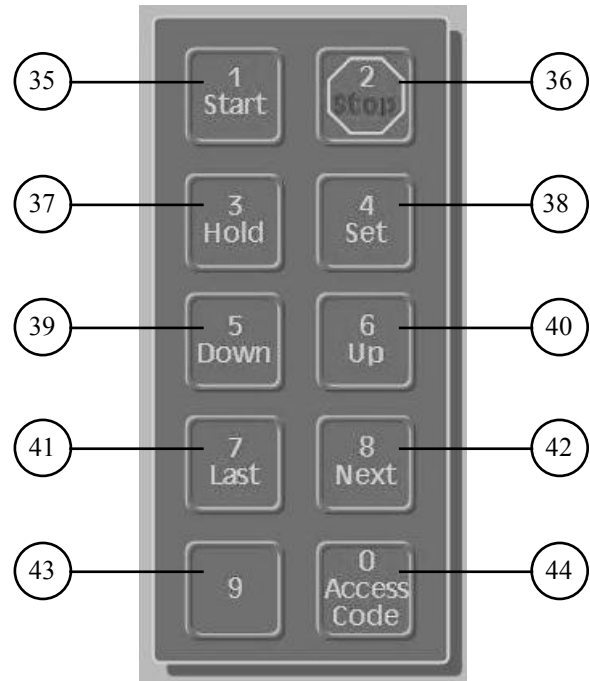

**Figure 2 - Keypad**

Moving into or out of the **Auxiliary Functions** readout without saving a changed parameter will revert back to the original value.

The **Auxiliary Functions** readout can display three real time operating values; T-R KW consumption, SCR Conduction Angle, and **LOGIC** board temperature. The **Last** and **Next** keys will select the desired parameter for the readout. KW has no associated setpoint, but the SCR Conduction Angle, Temperature, data link Unit



Number, and data link Access do. To display these setpoints, first select the item in the display using the **Last** or **Next** keys, then press the **Set** key. This will change the display to the setpoint.

Remember that a new limit may only be entered if a fast flashing LED is present in the indicator for the limit to be set. See the following sections for details of setting the various parameters.

A limit or parameter can be changed to a temporary setting during normal operation. Select and change the parameter as desired, but do not push the **Set** key after using the **Up** or **Down** keys. Do not use the **Next** or **Last** keys or the temporary setting will revert back to the original value. Temporary settings not locked in with the **Set** key will time out in *five minutes* and revert to the original limits.

The following sections are listed in the automatic access order resulting from using the **Next** key to access Primary Current Limit.

## 9.1 Primary Current Limit

Push the **Next** or **Last** key until the **T-R Primary Amps Limit** indicator (*figure 1, item 2*) flashes rapidly. This indicates that the displayed value is the setpoint limit and the limit may be adjusted.

Using the **Up** or **Down** keys, set the displayed limit to the T-R nameplate primary current rating for the connected T-R primary tap. When the correct value is displayed, press the **Set** key to save the new value in non volatile memory. If the value has changed, the flashing LED will automatically move to the next parameter in the direction last moved to acknowledge the new value has been saved.

**NOTE:** *Set Primary Current Limit to approximately 50% of T-R nameplate for initial startup.*

If the current reaches the T-R Primary Current Limit during operation, the **T-R Primary Amps Limit** indicator will flash about once per second indicating that the current limit has been reached but not exceeded. If the limit is exceeded and cannot be corrected by the MVC-IV, the control will trip off and the **T-R Primary Amps Limit** indicator will remain on.



## 9.2 Primary Over Voltage Limit

Push the **Next** or **Last** key until the **T-R Primary Volts Limit** indicator (*figure 1, item 5*) flashes rapidly indicating that the displayed value is the setpoint limit and it may be adjusted. Using the **Up** or **Down** keys, set the displayed limit to the T-R nameplate primary voltage rating for the connected T-R primary tap. When the correct value is displayed, press the **Set** key to save the new value in non volatile memory. If the value has changed, the flashing LED will automatically move to the next parameter in the direction last moved to acknowledge the new value has been saved.

If the primary voltage reaches the Primary Voltage Limit during operation, the **T-R Primary Volts Limit** indicator will flash about once per second indicating that the limit has been reached but not exceeded. If the limit is exceeded and cannot be corrected, the control will trip off and the **T-R Primary Volts Limit** indicator will remain on.

## 9.3 Primary Low Voltage Limit

During an arcing or a shorted condition in the precipitator, the current rises and the voltage decreases in both the T-R set primary and the precipitator. A timed under voltage trip function prevents a shorted condition from causing T-R set or precipitator damage. Anytime the primary voltage falls below the primary setpoint value during operation, the **T-R Primary Volts Low** indicator will flash about once per second. If the primary voltage remains at or below the setpoint level for more than 30 seconds, the control will trip off and the **T-R Primary Volts Low** indicator will remain on.

To adjust the T-R Primary Voltage Low limit, push the **Next** or **Last** key until the **T-R Primary Volts Low** indicator (*figure 1, item 6*) flashes rapidly indicating that the displayed value is the setpoint limit and that it may be adjusted. Using the **Up** or **Down** keys, set the displayed limit to the desired under voltage trip point, usually in the range of 80 Volts to 120 Volts. When the desired value is displayed, press the **Set** key to save the new value in non volatile memory. If the value has changed, the flashing LED will automatically move to the next parameter in the direction last moved to acknowledge the new value has been saved.



# MVC IV VOLTAGE CONTROL MANUAL

NEUNDORFER PRECIPITATOR KNOWLEDGE



## 9.4 Secondary Current Limit

Push the **Next** or **Last** key until the **T-R Secondary Amps Limit** indicator (*figure 1, item 8*) flashes rapidly, indicating that the displayed value is the setpoint limit and the limit may be adjusted. Using the **Up** or **Down** keys, set the displayed limit to the T-R nameplate secondary current rating. For T-R sets with secondary current ratings that vary with the connected T-R primary tap, use the highest listed secondary current. If the nameplate value is given in milliamperes (mA.), divide by 1000 to convert to Amperes. When the correct value is displayed, press the **Set** key to save the new value in non volatile memory. If the value has changed, the flashing LED will automatically move to the next parameter in the direction last moved to acknowledge the new value has been saved.

**NOTE:** *Set Secondary Current Limit to approximately 50% of T-R nameplate for initial startup.*

If the secondary current reaches the setpoint value during operation, the **Secondary Amps Limit** indicator will flash about once per second indicating that the maximum limit has been reached. If the limit is exceeded for approximately 7 seconds, the control will trip off and the **Secondary Amps Limit** indicator will remain on.

## 9.5 Rap Limit

In some cases reducing or turning off precipitator power enhances rapping efficiency. The RAP LIMIT is an auxiliary T-R Secondary Current Limit used to implement Reduced Power Rapping or Power Off Rapping (RPR / POR). The RAP LIMIT can be activated by a 120V AC or DC input or contact closure from a rapper control. When the MVC-IV receives an RPR command, it will reduce the secondary current to the RAP LIMIT setpoint. If the RAP LIMIT is set to zero, primary power will be removed from the T-R set during the POR interval. Low T-R voltage during an RPR interval will not cause an under voltage trip.

To adjust the RAP LIMIT, push the **Next** or **Last** key until the **T-R Secondary Amps Rap Limit** indicator (*figure 1, item 9*) flashes rapidly indicating that the displayed value is the setpoint and that it may be adjusted. Using the **Up** or **Down** keys, set the displayed limit to the desired RPR value. When the desired value is displayed, press the **Set** key to save the new value in non volatile memory. If the value has changed, the flashing LED will automatically move to the next parameter in the direction last moved to acknowledge the new value has been saved.

If the secondary current reaches the RAP LIMIT setpoint value during RPR operation, the **Secondary Amps Rap Limit** indicator will flash about once per second indicating that the RPR setpoint is limiting T-R set secondary current.



## 9.6 Secondary KV Over Voltage Limit

Push the **Next** or **Last** key until the **T-R Secondary KV Limit** indicator (*figure 1, item 12*) flashes rapidly, indicating that the displayed value is the setpoint limit and it may be adjusted. Using the **Up** or **Down** keys, set the displayed limit to the T-R nameplate secondary kilovolt rating. For T-R sets with secondary kilovolt ratings that vary with the connected T-R primary tap, use the highest listed secondary kilovolts. If the nameplate value is given in volts, divide by 1000 to convert to kilovolts (KV). When the correct value is displayed, press the **Set** key to save the new value in non volatile memory. If the value has changed, the flashing LED will move to the next parameter to acknowledge the new value has been saved. The entered limit is used for both bushings of a dual bushing T-R set.

If the secondary voltage reaches the setpoint value during operation, the **T-R Secondary KV Limit** indicator will flash about *once per second* along with the “A” or “B” LED (*figure 1, item 11*) for the offending bushing(s) indicating that the limit has been reached. If the limit is exceeded and cannot be corrected by the MVC-IV, the control will trip off and the **T-R Secondary KV Limit** indicator will remain on. The “A” or “B” LED will also illuminate to indicate the over limit bushing(s).

## 9.7 Secondary KV<sub>a</sub> Low Voltage Limit

During an arcing or a shorted condition in the precipitator, the current rises and the KV decreases. A timed under voltage trip function prevents a shorted condition from causing T-R set or precipitator damage. Anytime the bushing “A” KV falls below the setpoint value during operation, the **T-R Secondary KV Low** indicator will flash about once per second along with the “A” indicator. If KV<sub>a</sub> remain at or below the setpoint level for more than 30 seconds, the control will trip off and the **T-R Secondary KV Low** and “A” indicators will remain on.

To adjust the T-R Secondary KV<sub>a</sub> Low limit, push the **Next** or **Last** key until the **T-R Secondary KV**

“A” indicator lights and the **T-R Secondary KV Low** indicator (*figure 1, items 11 & 13*) flashes rapidly indicating that the displayed value is the setpoint limit and that it may be adjusted. Using the **Up** or **Down** keys, set the displayed limit to the desired under voltage trip point, usually in the range of 5 KV to 10 KV. When the desired value is displayed, press the **Set** key to save the new value in non volatile memory. If the value has changed, the flashing LED will automatically move to the next parameter in the direction last moved to acknowledge the new value has been saved.

Setting the T-R Secondary KV<sub>a</sub> Low limit to 0.1 KV - 1.0 KV provides KV<sub>a</sub> monitoring, but disables KV bushing “A” under voltage trips.

Setting the T-R Secondary KV<sub>a</sub> Low limit to zero (“OFF”) disables KV bushing “A” monitoring and KV<sub>a</sub> under voltage trips.

## 9.8 Secondary KV<sub>b</sub> Low Voltage Limit

Anytime the bushing “B” KV falls below the setpoint value during operation, the **T-R Secondary KV Low** indicator will flash along with the “B” indicator. If KV<sub>b</sub> remain at or below the setpoint level for more than 30 seconds, the control will trip off and the **T-R Secondary KV Low** and “B” indicators will remain on.

To adjust the T-R Secondary KV<sub>b</sub> Low limit, push the **Next** or **Last** key until the **T-R Secondary KV “B”** indicator lights and the **T-R Secondary KV Low** indicator (*figure 1, items 11 & 13*) flashes rapidly indicating that the displayed value is the setpoint limit and that it may be adjusted. Using the **Up** or **Down** keys, set the displayed limit to the desired under voltage trip point. When the desired value is displayed, press the **Set** key to save the new value in non volatile memory. If the value has changed, the flashing LED will automatically move to the next parameter in the direction last moved to acknowledge the new value has been saved.





# MVC IV VOLTAGE CONTROL MANUAL

NEUNDORFER PRECIPITATOR KNOWLEDGE



Setting the T-R Secondary KVb Low limit to 0.1 KV - 1.0 KV provides KVb monitoring, but disables KV bushing "B" under voltage trips.

Setting the T-R Secondary KVb Low limit to zero ("OFF") disables KV bushing "B" monitoring and KVb under voltage trips.

## 9.9 Baseline Spark Rate

The MVC-IV uses the Baseline Spark Rate as the value it will strive to maintain during stable precipitator conditions. A higher or lower spark rate may occur, however, depending on precipitator operating conditions. If a T-R nameplate limit, Conduction Angle Limit, Back Corona Control limit, AutoMax limit or RPR is reached below the spark threshold of the precipitator, the spark rate will fall below the setpoint. When the MVC-IV detects unstable precipitator conditions, the proprietary adaptive control algorithms may increase the spark rate to maintain optimum precipitator power input.

Push the **Next** or **Last** key until the **Response Spark** indicator (*figure 1, item 15*) flashes rapidly, indicating that the displayed value is the sparks per minute baseline rate and that it may be adjusted. Using the **Up** or **Down** keys, set the displayed setpoint to the desired value. When the desired value is displayed, press the **Set** key to save the new value in non volatile memory. If the value has changed, the flashing LED will automatically move to the next parameter in the direction last moved to acknowledge the new value has been saved.

Pressing the **Set** key without changing the Spark Rate generates a spark simulation, causing the MVC-IV to execute its normal spark response algorithm.

The **Spark** indicator flashes for each spark event.

**NOTE: If Intermittent Energization (IE) is enabled, the Baseline Spark Rate cannot be set above 60 sparks per minute. To set higher Spark Rates, set the IE ratio to "OFF". See section 9.13.**

## 9.10 Setback

As part of spark response, depending on spark response mode, the T-R primary power is reduced by the Setback factor below the power level at which the spark occurred.

The Setback factor is a self adaptive control parameter designed to achieve stable operation free from restrikes. The Setback factor is a guide number representing an approximate percentage reduction in conduction angle when the T-R set is operating near Primary Current Limit. The MVC-IV will automatically change the setback percentage according to its algorithm at other power levels.

Push the **Next** or **Last** key until the **Response Setback** indicator (*figure 1, item 16*) flashes rapidly, indicating that the displayed value is the Post Spark Setback factor and that it may be adjusted. Using the **Up** or **Down** keys, set the displayed setpoint to the desired value. When the correct value is displayed, press the **Set** key to save the new value in non volatile memory. If the value has changed, the flashing LED will automatically move to the next parameter to acknowledge the new value has been saved.

The available Setback settings are 1%, 2%, 5%, 10%, 15%, 20%, and 25%. Inlet fields and fields that spark excessively need a higher Setback to maintain stable operation, typically 10% to 20%. Outlet fields and fields with stable spark over voltage typically use a lower Setback in the 2% to 10% range.

The **Setback** indicator blinks when post spark setback has reached the maximum possible, that is, conduction angle has been reduced to the minimum achievable value of 20 degrees.





# MVC IV VOLTAGE CONTROL MANUAL

NEUNDORFER PRECIPITATOR KNOWLEDGE



## 9.11 Spark Response Mode

The MVC-IV provides a choice of four different Spark Response Modes. *Figure 4* shows typical response patterns for each mode.

**MODE 1** - The MVC-IV quenches every spark, counts one spark; fast ramps to the Setback level, and slow ramps back to the next spark.

**MODE 2** - The control ignores the first spark. If a second spark occurs during the next one-half cycle of **SCR conduction**, the MVC-IV quenches the spark, counts one spark, fast ramps to the Setback level, and slow ramps back to the next spark.

### CAUTION

**Do not use Mode 2 with a dual bushing T-R set operating in double half wave.**

**MODE 3** - The control only takes corrective action if sparks occur on three consecutive half cycles of **SCR conduction**. Then the MVC-IV quenches the spark, counts one spark, fast ramps to the Setback level, and slow ramps back to the next spark.

### CAUTION

**Do not use Mode 3 with a dual bushing T-R set operating in double half wave.**

**Mode 4** - Provides a setback of the conduction angle without a quench for the first occurrence of a spark. If there is another spark on the next half cycle of **SCR ON** time, there will then be a quench and ensuing fast ramp without an additional setback. Only the spark causing the setback is counted in the digital SPM readout.

**Mode 1** is used on precipitators which produce high intensity sparks. **Mode 2** would be used if spit sparking was occurring with some high intensity sparks. **Mode 3** is used in the case of very low

intensity sparking. **Mode 4** may increase collection efficiency for any precipitator that has significant low energy sparking.

A storage oscilloscope should be connected to secondary current to monitor the intensity of the sparks and determine which mode should be used.

Push the **Next** or **Last** key until the **Spark Monitor Mode** indicator (*figure 1, item 17*) flashes rapidly, indicating that the displayed value is the Spark Response Mode and that it may be adjusted. Using the **Up** or **Down** keys, select the desired mode. When the desired value is displayed, press the **Set** key to save the new value in non volatile memory. If the value has changed, the flashing LED will automatically move to the next parameter in the direction last moved to acknowledge the new value has been saved.



## 9.12 Back Corona Control Software

Back corona is an undesirable operating condition that can reduce collection efficiency and increase power consumption. Preventing back corona can improve precipitator collection efficiency.

The MVC-IV Back Corona Control software, when enabled, maintains the maximum operating level possible below the onset of back corona. The algorithm senses back corona by analysis of enabled KV bushings. For this feature to function the low pass filter jumpers, JP71 and JP81, on the LOGIC board must be removed or placed in the storage position.

If the algorithm senses back corona, it responds by initiating a four half cycle quench and a setback. The effect is to limit T-R operation to a point just below the onset of back corona.

The Back Corona software can only be enabled when Intermittent Energization is disabled. See [section 9.13](#).

**NOTE: The MVC-IV must have secondary KV feedback for operation of the Back Corona software. Enabling the Back Corona software without KV feedback will have no effect on system operation.**

When the Back Corona software is enabled, the **Back Corona** indicator ([figure 1, item 18](#)) is illuminated. If back corona is detected, the **Back Corona** indicator light blinks off momentarily to indicate MVC-IV is making a corrective response to limiting T-R operation below back corona onset.

If back corona is not detected, the status indicator remains on steady to indicate that the Back Corona software is enabled.

To enable or disable the Back Corona software, push the **Next** or **Last** key until the **Response Back Corona** indicator ([figure 1, item 18](#)) flashes rapidly indicating that the displayed value is the Back Corona Control setting and that it may be adjusted. If the **Response** readout shows "-- --",

IE is enabled, locking out the Back Corona program. Refer to [section 9.13](#) to resolve.

Use the **Up** or **Down** keys to select the Back Corona software control setting between. Depending on firmware version, the available settings may be limited to "**OFF**" and "**on**" or the choices may include a numerical value. Presently settings of "**on**" or numerical setting "**1**" are effective. Any other setting will disable the Back Corona program. Press the **Set** key to save the new selection in non volatile memory. If the setting has changed, the flashing LED will move to the next parameter to acknowledge the new value has been saved.



## 9.13 IE Ratio Settings

IE refers to **Intermittent Energization**, a T-R energization process that rapidly cycles power on and off to the T-R set. IE can reduce power consumption and may prevent back corona which will increase collection efficiency. The IE program controls power flow to the T-R set in half cycle of the line increments, repeating the selected **ON** and **OFF** periods.

Power can be applied in 1, 2 or 3 half cycles of the line increments. The power **OFF** time can only be selected as 2, 4, 6, 8, 10, 12 ... 62 half cycles of the line to prevent net DC in the T-R set primary. For an example setting of 2.06, the digit to the left of the decimal (2) refers to the number of **ON** half cycles. The two digits to the right of the decimal point (06) represent the number of **OFF** half cycles.

It is strongly recommended to use 1 or 3 half cycles of **ON** time when running T-R sets in full wave and to use 1 or 2 half cycles of **ON** time for T-R sets running in double half wave. If Intermittent Energization is configured for two half cycles of **ON** time with full wave operation, it will likely produce a net DC current in the T-R primary due to high recharge current in the first of the two half cycles of **ON** time.

Operating experience will help achieve the optimum setting. Setting the IE ratio to "0.00" or "OFF" disables the IE feature. To activate IE, the Spark Rate must be at or below 60 SPM and the Back Corona software must be disabled. See [sections 9.9 and 9.12](#).

The spark rate is automatically reduced further for long **IE OFF** times to ensure a few stable **IE** cycles at the slow ramp rate before the next spark.

Also, to accommodate the long **IE OFF** periods, an adaptive digital display averaging program provides optimum smoothing and response for the digital readouts at all **IE** duty cycles.

To enable, disable or adjust the IE software, push the **Next** or **Last** key until the **Response IE**

indicator (*figure 1, item 19*) flashes rapidly indicating that the displayed value is the Intermittent Energization control code and that it may be adjusted. If the **Response** readout shows "- - -" or cannot be enabled, either the Baseline Spark Rate is above 60 SPM or the Back Corona software is enabled, locking out the IE feature. Refer to [sections 9.9 and 9.12](#) to resolve.

Using the **Up** or **Down** keys, select the desired IE ratio. When the desired setting is displayed, press the **Set** key to save the new number in non volatile memory. If the value has changed, the flashing LED will move to the next parameter to acknowledge the new value has been saved.

### 9.13.1 T-R Operating Limits With IE

The safe operating limits established by the T-R set nameplate are determined by temperature rise, safe rectifier current and voltage, and magnetic saturation limits. When IE is in operation, the MVC-IV will strictly adhere to these limits during *any actual conduction period*. There is no need to make any other adjustments to accommodate IE. Because the front panel displays represent a time averaged value, it is normal to see status indicators showing operation at a limit while the readout value is significantly below the limit.

**CAUTION**

**Do not re-adjust the limits to achieve rated nameplate operating values during IE operation.**

**Do not attempt to verify MVC-IV calibration with IE operating.**



## 9.14 AutoMax Setting

*This is a future planned feature for the MVC-IV and is not yet implemented. It is subject to change.*

The AutoMax feature automatically adjusts MVC-IV operating parameters to achieve the highest possible KV level.

Push the **Next** or **Last** key until the **Response AutoMax** indicator (*figure 1, item 20*) flashes rapidly, indicating that the displayed value is the AutoMax setting and that it may be adjusted. Using the **Up** or **Down** keys, change the setting between "**on**" and "**OFF**" as desired. When the desired setting is displayed, press the **Set** key to save the new setting in non volatile memory. If the setting has changed, the flashing LED will automatically move to the next parameter in the direction last moved to acknowledge the new setting has been saved.

**NOTE:** *The MVC-IV must have secondary KV feedback for operation of the AutoMax software. Enabling the AutoMax software without KV feedback will have no effect on system operation.*



# MVC IV VOLTAGE CONTROL MANUAL

NEUNDORFER PRECIPITATOR KNOWLEDGE



## 9.15 Kilowatts

Push the **Next** or **Last** key until the **KW** indicator (*figure 1, item 22*) is illuminated indicating that the displayed value in the **Auxiliary Functions** digital readout is the T-R set primary kilowatt power consumption or secondary kilowatt power output. The displayed primary value excludes power losses in the CLR, SCR stack and peripheral circuitry. It is a read only value and has no associated setpoint. The indicated value is true Kilowatts calculated from the T-R set feedback signals, not simply the KVA product.

The software Options Code setup (*see section 8.1*) allows selecting Primary or Secondary KW.

## 9.16 Conduction Angle

This feature allows monitoring the SCR Conduction Angle and setting an upper limit for the Conduction Angle. It may be used as a manual control and for taking V-I curve data. In installations where T-R sets and CLR's are not ideally matched, the Conduction Angle Limit is used to prevent saturation of the magnetic components.

Push the **Next** or **Last** key until the **Cond. Angle** indicator (*figure 1, item 23*) is illuminated indicating that the displayed value in the **Auxiliary Functions** digital readout is the SCR Conduction Angle. When the T-R is energized, a reading from 20 to 160, representing minimum to full power, will be displayed. To adjust the upper limit setpoint or place the MVC-IV in manual control, push the **Set** key. The **Cond. Angle** LED will flash rapidly, indicating that the displayed value is the Conduction Angle setpoint and that it may be adjusted. Using the **Up** or **Down** keys, select the desired Conduction Angle. If the new value is to be saved in non volatile memory as an operating limit, again press the **Set** key. If the value has changed, the flashing LED will move to the next parameter in the direction last moved, acknowledging the new value has been saved.

The Conduction Angle Limit is an upper limit only. It cannot be used to force MVC-IV operation above the other limits or the sparking level. The **Cond. Angle** indicator will flash about once per second when conduction angle is at the setpoint.



# MVC IV VOLTAGE CONTROL MANUAL

NEUNDORFER PRECIPITATOR KNOWLEDGE



## 9.17 Temperature

This feature monitors the local temperature on the main **LOGIC** board and provides an adjustable alarm limit setting. It has no effect on controller operation.

Push the **Next** or **Last** key until the **Temp. °F** indicator (*figure 1, item 24*) is illuminated indicating that the displayed value in the **Auxiliary Functions** digital readout is the **LOGIC** board Temperature. To adjust the alarm limit setpoint, push the **Set** key. The **Temp. °F** LED will flash rapidly, indicating that the displayed value is the alarm setpoint and that it may be adjusted. Using the **Up** or **Down** keys, select the desired alarm temperature. If the new value is to be saved in non volatile memory as an alarm limit, again press the **Set** key. If the value has changed, the flashing LED will move to the next parameter in the direction last moved, acknowledging the new value has been saved.

## 9.18 Data Link Unit Number

**Data Link unit number changes can only be made using a direct connected DISPLAY.**

The Data Link Unit Number assigns a *unique* address or unit number to each MVC-IV in a data communications network. A computer system such as the Neundorfer POS or a DCS uses the Data Link Unit Number to access each controller on a party line communications network. Unit numbers must be assigned sequentially starting with number one, and there can be no missing numbers. The order of assignment must be coordinated with POS or DCS definitions of unit assignments for proper communications and display results. The unit number assignment is also used to stagger the automatic restart of MVC-IV's after a power failure. See *section 10.1*.

Push the **Next** or **Last** key until the **Data Link** indicator (*figure 1, item 25*) is illuminated and the **Auxiliary Functions** digital readout is showing a numerical value indicating that the displayed value

is the Data Link Unit Number. To adjust the Unit Number, push the **Set** key. The **Data Link** LED will flash rapidly, indicating that the displayed value may be adjusted. Using the **Up** or **Down** keys, select the desired unit number. When the desired number is displayed, press the **Set** key to save the new number in non volatile memory. If the value has changed, the flashing LED will automatically move to the next parameter in the direction last moved to acknowledge the new value has been saved.

## 9.19 POS Access Enable

POS Access Enable is also associated with the **Data Link** indicator (*figure 1, item 25*). Use the **Next** or **Last** key to access the Unit number. Then push **Next** one more time to select the POS Access Enable status. The **Auxiliary Functions** digital readout will show "**OFF**", "**on**" or "**EnR**".

"**OFF**" prevents MVC-IV from answering any POS messages. Firmware version 2.1b and later disconnects all communication circuitry except the terminator from the data link in the "**OFF**" setting.

"**on**" allows POS to read data from the MVC-IV, but does not allow POS to make any changes.

"**EnR**" gives POS full access to all MVC-IV setpoints and configuration parameters.

To adjust the Access Level, first push the **Set** key. Using the **Up** or **Down** keys, select the desired level of POS access. When the desired setting is displayed, press the **Set** key to save the new setting in non volatile memory. If the setting has changed, the flashing LED will automatically move to the next parameter in the direction last moved to acknowledge the new value has been saved.

The **Data Link** indicator also indicates activity on the data link, by flashing briefly when a POS messages is transmitted.





# MVC IV VOLTAGE CONTROL MANUAL

NEUNDORFER PRECIPITATOR KNOWLEDGE



## 10.0 ADDITIONAL FEATURES

### 10.1 Operation of Auto Restart

The MVC-IV has a user configurable option (*see section 8.1*) that, when enabled, provides automatic restart of the MVC-IV upon power restoration if the control was running when power failed and if the **T-R On** switch circuit is closed when power is restored. The auto restart features a rapid ramp rate to quickly restore precipitator power. Startup of

controls is staggered by unit number, so it is important to set the MVC-IV unit numbers sequentially.

*The following table shows results at power on assuming all permissives are present.*

Control status at power down	Status of T-R On switch when power is restored	AUTO RESTART option	Control status after diagnostic self test concludes
STOPPED or RUNNING	OFF Position	Disabled	Trip LED's and relay are off, <b>T-R On</b> LED is off, <b>T-R Off</b> LED is on and ALARM RELAY is set. Control in standby mode & ready to run.
STOPPED or RUNNING	ON Position	Disabled	Trip LED's and relay are off, <b>T-R On</b> LED is off, <b>T-R Off</b> LED is on and ALARM RELAY is set. Control in standby. To start control, cycle <b>T-R On</b> switch off then on or press " <b>Start</b> " key.
STOPPED or RUNNING	OFF Position	Enabled	Trip LED's and relay are off, <b>T-R On</b> LED is off, <b>T-R Off</b> LED is on and ALARM RELAY is set. Control in standby & ready to run.
STOPPED	ON Position	Enabled	Trip LED's and relay are off, <b>T-R On</b> LED is off, <b>T-R Off</b> LED is on and ALARM RELAY is set. Control in standby. To start control, cycle <b>T-R On</b> switch off then on or press " <b>Start</b> " key.
RUNNING	ON Position	Enabled	Trip LED's and relay are off, <b>T-R Off</b> LED is off and ALARM RELAY is clear, <b>T-R On</b> LED is on. Control automatically resumes operation.

Table 11 - Auto Restart Operation





## 10.2 Display Hold Feature

During normal operation the MVC-IV facepanel displays the real time T-R operating values. If the MVC-IV trips off because it is unable to correct an out-of-limit condition or due to an **External Trip** input signal, the **DISPLAY** values will freeze to show the values present at the time of the trip. One or more status LED indicators will be illuminated showing the reason for the trip. The entire **DISPLAY** will flash about twice per second to attract operator attention. After noting the cause of the trip, the system can be reset by opening the **T-R On** switch, by pressing the **Stop** key, by activating the **Remote Stop** or **ACK Alarm** inputs, or via data link commands. Resetting the MVC-IV changes the **DISPLAY** back to the static display of the setpoint values. Pressing the **Hold** key will recover the facepanel readings at the time of the trip, but without the **DISPLAY** flashing. The **DISPLAY** will not freeze if the control trips due to a power interruption.

While the control is running, it may be difficult to take accurate readings from the digital readouts. Pressing the **Hold** key will freeze the displays at their current values. This will have no effect on control operation. Pressing the **Hold** key again will unfreeze the **DISPLAY**.

## 10.3 Dual Bushing Kilovolt Metering

For MVC-IV controls configured for dual bushing KV operation, the keypad **Up** and **Down** keys are used to select the desired bushing for display in the **T-R Secondary KV** readout. With the control running and no status indicators fast blinking, that is, no limits are available for adjustment, pressing the **Up** key selects bushing “B” and pressing the **Down** key selects bushing “A”. Regardless of which bushing is displayed, operation of the T-R is regulated to keep both bushings within the set KV upper limit, and both (if enabled) are monitored for under voltage. See [sections 9.7 and 9.8](#) for enabling and disabling KV<sub>a</sub> and KV<sub>b</sub> bushings.

## 10.4 Auxiliary Functions Display Default Parameter

The **Auxiliary Functions** readout can be set to display KW, Conduction Angle, Temperature or Unit number as the default parameter.

If any of these parameters is displayed in the **Auxiliary Functions** digital readout when the MVC-IV is stopped, that parameter will become the new display default parameter. The default is used on startup or any time the keypad times out. The new default will be used until changed again.

## 10.5 Auto Spark Quench Interval

The MVC-IV automatically adjusts the quench time needed to extinguish sparking and prevent restrikes. It normally maintains the minimum possible quench time of two half cycles (16.7 msec). This maximizes power levels, improving collection efficiency. When restrikes are detected the MVC-IV will extend the quench time to 4, 6 or 8 half-cycles as needed. See [figures 4 and 5](#) for waveforms. When normal sparking occurs without restrikes it will reduce the quench time back toward the two half cycle minimum.



## 10.6 RS-485 Communications

The MVC-IV can communicate via a multi-drop, serial communications network with a POS computer, DCS or other host computer system. Up to 238 voltage controls can be connected together in the network. The MVC-IV local and remote LAN display(s) also utilizes an RS-485 link to communicate with the logic board.

Data communications within a local group of controllers uses RS-485 electrical standards on twisted pair cable. To avoid possible ground offset problems, communications beyond a local room requires electrical isolation. Our preferred method is with fiber optic cable, although electrically isolated RS-485 repeaters could also be used.

Each fiber optic converter or RS-485 repeater can power the data line for at least 32 individual voltage controls. Any combination of repeaters and drop points can be used as long as the total number of voltage controls does not exceed 238 and no RS-485 device is directly connected to more than 32 devices.

*Drawing 8-01-0222* shows a typical data link network.

The physical ends of each data link RS-485 cable must be terminated for reliable data link operation. Refer to the Neundorfer or other equipment user manual for the devices at the physical ends of the data link cable for the termination method. *Section 11.1* and *figure 3* provide information for setting the MVC-IV data link termination jumpers.

If the terminating device is powered down, its network biasing circuit will be inoperative. The termination network, however, remains operative. If practical, a powered down terminating device should be removed from the data link. To ensure reliable data link communications, the data link cable should be terminated by the last powered device at the physical ends of the data link cable.

*Section 15.6* provides data link troubleshooting information and diagnostic waveforms.



# MVC IV VOLTAGE CONTROL MANUAL

NEUNDORFER PRECIPITATOR KNOWLEDGE



## 10.7 Data Link Start, Stop, Reset (ACK Alarm)

With the Run Request circuit closed, the MVC-IV can be stopped, started, or reset from trips (alarm acknowledge) via data link commands. Opening the front panel **T-R On** switch (Run Request circuit) or opening the **Permissive** input will always override the data link commands and stop the MVC-IV. These commands are standard functions of the Neundorfer POS or can be issued by a properly programmed host computer. To use the data link commands, POS access must be enabled (see section 9.19) and the MVC-IV **T-R On** switch (Run Request circuit) (section 6.3) must be closed.

Following is the result of each command:

Command	MVC-IV condition	Result
Start	On	----
	Off	Start
	Tripped	----
Stop	On	Stop
	Off	----
	Tripped	Reset
Reset (Ack Alarm)	On	----
	Off	----
	Tripped	Reset

Table 12 - Data Link Start / Stop Operation

## 10.8 Remote Start, Stop, ACK Alarm

With the Run Request circuit closed, the MVC-IV can be stopped, started, or reset from trips (alarm acknowledge) using the **Remote Stop**, **Remote Start**, or **ACK Alarm** opto coupler isolated inputs. The action takes place on the transition of the input, so these inputs may be operated with momentary or maintained contacts. The inputs can be configured to operate on either presence or absence of signal. Refer to section 8.5 for configuring the inputs.

Refer to drawing 8-01-0229 for connection to these inputs. Opening the front panel **T-R On** switch (Run Request circuit), opening the **Permissive** input, or asserting the **Remote Stop** input will always override all other inputs and stop the MVC-IV. To use the **Remote inputs**, the **T-R On** switch (Run Request circuit) (section 6.3) must be closed.

With the Remote inputs, controls can be started or stopped in groups using a single momentary or maintained switch for each function. The **Remote Start** and **Stop** inputs can be configured to also provide a simultaneous **Ack Alarm** function.

Following is the result of asserting each input:

Input	MVC-IV condition	Result
Start	On	----
	Off	Start
	Tripped	----
Stop	On	Stop
	Off	----
	Tripped	----
Ack Alarm	On	----
	Off	----
	Tripped	Reset

Table 13 - Remote Start / Stop Operation



## 10.9 Alarm Relays

The MVC-IV provides two Alarm Relays with three possible functions.

### 10.9.1 Trip Alarm Relay K2

K2 is energized when an internally or externally generated control trip occurs including loss of **Permissive** and CMR trips. Opening the **T-R On** switch, pressing the **Stop** key, activating the **ACK Alarm** contact inputs, or sending a data link STOP or RESET command will clear the alarm. K2 provides a form C contact.

### 10.9.2 Relay K3

K3 is user configurable to provide two different functions according to system needs. For systems without a main contactor, K3 is energized to open shunt trip or motorized T-R supply breakers when the MVC-IV detects an uncorrectable T-R run away condition.

After any MVC-IV trip condition, the microprocessor continues to monitor T-R set primary current and primary voltage signals for non-zero values indicating a run away condition. This could happen in an installation that does not have a contactor and relies on the SCR's alone to stop power flow to the T-R set. Without a contactor, a shorted SCR would make it impossible for the MVC-IV to stop power flow to the T-R set. If a run away condition is detected, the microprocessor will activate K3 to open the T-R supply breaker.

Since a run away condition is considered a catastrophic failure requiring repair, once K3 has been activated, **it will remain activated until the MVC-IV cabinet power is removed**. All operator inputs and POS control will be disabled until cabinet power is removed and restored. The **Auxiliary Functions** display will show the code HLP and a status code will be sent to POS indicating the MVC-IV has shut down due to a run away condition. The MVC-IV displays and the status indicators (except the **Auxiliary Functions**

display) will show the conditions at the time of the original trip before the run away was detected. If K3 is used to trip the supply breaker, the control power should be provided from a source ahead of the breaker that will be tripped by K3.

For controls with contactors, the Trip Breaker function is not needed, and K3 can be configured to provide a T-R off alarm by being de-energized whenever the T-R set is off. See [section 8.1](#).

K3 provides a form C contact.



# MVC IV VOLTAGE CONTROL MANUAL

NEUNDORFER PRECIPITATOR KNOWLEDGE



This page intentionally blank.



# MVC IV VOLTAGE CONTROL MANUAL

NEUNDORFER PRECIPITATOR KNOWLEDGE



## 11.0 INITIAL STARTUP

### **! WARNING**

**Voltages and currents capable of causing death are present in the T-R control cabinet and at the T-R set!**

### **CAUTION**

To prevent damage to the equipment, ensure that the continuity test has been performed and that continuity exists in all connections shown in the schematic diagram, before turning on main power to the T-R control cabinet.

Verify that the proper T-R set grounding connections and surge suppresser have been installed in the ground leg of the T-R set high voltage bridge. *See sections 4.2.1, 5.3.2, and 5.4.3 and drawings 8-01-0223 and 8-01-0224.*

Part of initial startup is verification of T-R operating parameter metering accuracy. While there are no calibration adjustments, significant metering errors would indicate installation errors, control setup errors, or failed components. It is, therefore, suggested to perform calibration checks on each new control installation.

The following equipment is required to perform the startup and calibration verification procedure:

1. TRUE RMS clamp-on AC ammeter
2. TRUE RMS digital volt-ohmmeter with a 600 VAC range and a 0-5 VDC range
3. Calculator

Optional

4. Isolated input storage oscilloscope with inputs rated for 600 VAC. Each oscilloscope channel **must be isolated from all other channels and from earth ground.**

### **! WARNING**

**DO NOT USE A FLOATED SCOPE. A FLOATED SCOPE IS POTENTIALLY LETHAL!**





# MVC IV VOLTAGE CONTROL MANUAL

NEUNDORFER PRECIPITATOR KNOWLEDGE



## 11.1 Setting Circuit Board Jumpers

The main LOGIC board has a total of six micro jumpers to configure circuitry for the particular installation. Each micro jumper has a storage position (middle and bottom post) and an active position (upper and middle post). Refer to *figure 3* for location of each jumper. Normally LOGIC boards are shipped with all jumpers in the storage position.

This section identifies the function of all jumper options and may direct the user to other sections of the manual for more detailed information.

### 11.1.1 KV Feedback Circuit.

Two KV feedback configurations can be used with the MVC-IV. See *section 5.7* for more details.

Wiring connection choices at the INTERFACE PCB select between balanced and unbalanced KV feedback circuits. Jumpers JP71 and JP81 on the LOGIC PCB provide low pass filters for noisy KV signals resulting from using the unbalanced feedback circuit. If excessive electrical noise is observed on the KV waveform, move these jumpers from the storage position (down) to the active position (up).

*Drawing 8-01-0223, sheet 1* shows the acceptable wiring methods for KV feedback signals.

*Drawings 82200-104* provides information about the Neundorfer KV Signal Feedback Surge Suppression circuit board for the desired feedback wiring circuit.

At initial startup, if the control indicates continual sparking at minimum conduction angle, it is probably caused by excessive electrical noise on the KV feedback signal. Try installing jumpers JP71 and J81 in their active positions to correct the problem.

### 11.1.2 Display Data Link Jumpers

*(also see section 10.6.)*

*Figure 3* identifies the MVC-IV DISPLAY data link jumpers as JP102 and JP103, which activate the end-of-line terminator for the DISPLAY data link. These jumpers remain in their **inactive** (down) positions unless there is a network cable connected to one of J8 or J9 but not to both. If there is a network cable connected to **just one of J8 or J9**, then this LOGIC board is at the physical end of the cable, and JP102 and JP103 must be placed in their **active** (up) positions.

J8	J9	JP102	JP103
Unused	Unused	Inactive (dn)	Inactive (dn)
In use	In use	Inactive (dn)	Inactive (dn)
In use	Unused	Active (up)	Active (up)
Unused	In use	Active (up)	Active (up)

### 11.1.3 POS Data Link Jumpers

*Also see section 10.6.*

*Figure 3* identifies the MVC-IV POS data link jumpers as JP111 and JP112, which activate the end-of-line terminator for the POS data link. These jumpers remain in their **inactive** (down) positions unless there is a network cable connected to one of J11 or J12 but not to both. If there is a network cable connected to **just one of J11 and J12**, then this LOGIC board is at the physical end of the cable, and JP111 and JP112 must be placed in their **active** (up) positions.

J11	J12	JP111	JP112
Unused	Unused	Inactive (dn)	Inactive (dn)
In use	In use	Inactive (dn)	Inactive (dn)
In use	Unused	Active (up)	Active (up)
Unused	In use	Active (up)	Active (up)



# MVC IV VOLTAGE CONTROL MANUAL

NEUNDORFER PRECIPITATOR KNOWLEDGE

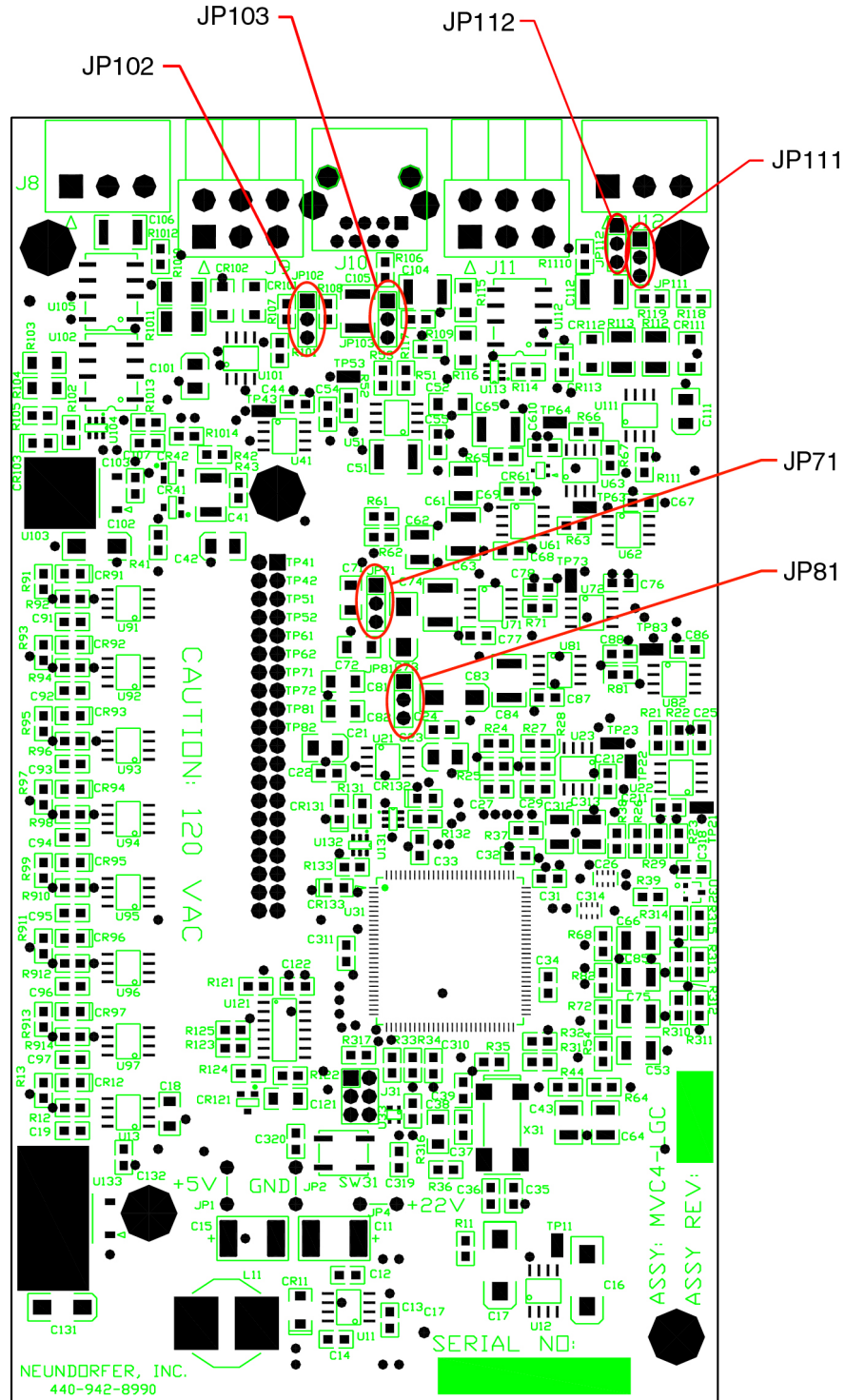

Figure 3 - MVC-IV Logic Board Jumper Identification



# MVC IV VOLTAGE CONTROL MANUAL

NEUNDORFER PRECIPITATOR KNOWLEDGE



## 11.2 Initial Turn On Settings

Turn the main circuit breaker on to apply 120V AC to the MVC-IV LOGIC board. The control will take about 8 seconds to complete its self test and **DISPLAY** test. If the self test does not conclude successfully refer to [section 15](#) for trouble shooting guides.

After the self test has successfully completed, place the MVC-IV into the System Setup Mode and verify correct setting of all configuration parameters. Refer to [sections 8.0 - 8.5](#) for complete instructions.

Press and release the **Stop** key to put the MVC-IV back into Standby Mode. Referring to [section 9.0 through 9.19](#) adjust all setpoints to the initial settings shown in [Table 14](#):

**CAUTION**

**The primary and secondary current limits should be set at 50% of the T-R nameplate current ratings until the initial turn on procedure is completed.**

Parameter	Setpoint Value	Manual Section
Primary Current Limit	50% of T-R nameplate	9.1
Primary Over Voltage Limit	T-R nameplate	9.2
Primary Low Voltage Limit	80 Volts	9.3
Secondary Current Limit	50% of T-R nameplate	9.4
Rap Limit	0.0 Amps	9.5
Secondary Over Voltage Limit	T-R nameplate - 10 KV	9.6
KVa Low Limit / Enable	8 KV or "OFF" as appropriate	9.7
KVb Low Limit / Enable	8 KV or "OFF" as appropriate	9.8
Baseline Spark Rate	15 SPM	9.9
Setback	5%	9.10
Spark Response Mode	1	9.11
Back Corona Software	"OFF"	9.12
IE Ratio Setting	"OFF"	9.13
AutoMax	"OFF"	9.14
Kilowatts	no setting	9.15
Conduction Angle	30 degrees	9.16
Temperature	120	9.17
Data Link Unit Number	Sequential as needed	9.18
POS Access Enable	"On"	9.19

**Table 14 - Initial Startup Setpoint Values**



# MVC IV VOLTAGE CONTROL MANUAL

NEUNDORFER PRECIPITATOR KNOWLEDGE



## 11.3 Calibration - General Information

### CAUTION

Before the MVC-IV is put into service, Primary Current, Primary Voltage, Secondary Current, and KV readouts should be checked for accurate display of T-R operating values.

The MVC-IV has no user calibration adjustments and should read T-R operating values accurate to within 5% of full T-R nameplate values. That means, for example, that a 200 Amp T-R set may have a maximum primary current metering error of 10 Amps at any operating level. If the T-R is operating well below rated current, the percent error may be significantly higher than 5% of the operating value.

Installation or control setup errors can, however, cause gross metering errors resulting in failure to control T-R operation within specified limits.

Checking MVC-IV metering accuracy against known calibrated instruments can reveal installation or setup errors that may have been undetected.

## 11.4 Primary Current Metering Check

### CAUTION

Verify that Conduction Angle Limit is set to 30 degrees or less before energizing the T-R set.

### WARNING

## 600 Volts

Place a TRUE RMS clamp-on ammeter around the T-R input power feed cable. Apply power to the T-R set by closing the **T-R On** switch. Use the Conduction Angle adjustment (*see section 9.16*) to manually raise the power level until the clamp-on ammeter reads about 50% of the primary current rating of the T-R set. If sparking occurs set the Conduction Angle low enough to prevent sparking.

Press the **Set** key to lock in the new Conduction Angle limit.

Verify that the value displayed in the **T-R Primary Amps** digital readout is no more than 5% of T-R nameplate primary Amps different from the value shown on the TRUE RMS clamp on meter. If the error exceeds 5% of T-R nameplate Amps, there is an error in the CT size setting (*see section 8.2*), a wiring error, or one of the circuit boards is defective. Correct the problem before proceeding.

De-energize the T-R set and turn off cabinet power.



# MVC IV VOLTAGE CONTROL MANUAL

NEUNDORFER PRECIPITATOR KNOWLEDGE



## 11.5 Primary Voltage Metering Check

**! WARNING**

**600 Volts**

Connect the TRUE RMS voltmeter across the primary side of the T-R set, excluding the current limiting reactor (CLR).

This reading can be taken in the cabinet at the input to the **INTERFACE** board at *J7* across terminals *1* to *2* (refer to drawing 8-01-0224, or 8-01-0229). Use the Conduction Angle Limit as set in previous section (also see section 9.16) to stabilize T-R operation below the spark threshold at approximately 50% of rated T-R primary current. Verify that the value displayed in the **T-R Primary Volts** digital readout agrees with the value shown on the TRUE RMS meter within 25 Volts. If the error is excessive, there is a wiring error or one of the circuit boards is defective. Correct the problem before proceeding.

De-energize the T-R set and turn off cabinet power

## 11.6 Secondary Current Metering Check

**! WARNING**

**600 Volts**

All secondary current flows through a precision 0.220 Ohm metering resistor on the **INTERFACE** board. Connect a DC Volt meter across the **INTERFACE** board connector *J6*, terminals *1* and *2*.

Use the Conduction Angle Limit as set in section 11.4 (also see section 9.16) to stabilize T-R operation below the spark threshold at approximately 50% of rated T-R primary current.

Measure the DC voltage  $V_{IN}$  between *J6*, terminals *1* and *2*. Divide that value by 0.220 to calculate secondary current in Amps. Verify that the value displayed in the **T-R Secondary Amps** digital readout agrees with the value calculate from the DC Volt meter reading within 5% of rated T-R secondary current. If the error is excessive, there is a wiring error or one of the circuit boards is defective. Correct the problem before proceeding.

De-energize the T-R set and turn off cabinet power

### Secondary Current Verification

With the control stabilizes below the spark threshold, read the DC voltage  $V_{IN}$  across the **INTERFACE** board between terminals *J6-1* and *J6-2*. The secondary current is given by:

$$SI = \frac{V_{IN}}{0.220}$$

Where: SI = secondary current in Amps  
 $V_{IN}$  is in volts between *J6-1* and *J6-2*



# MVC IV VOLTAGE CONTROL MANUAL

NEUNDORFER PRECIPITATOR KNOWLEDGE



## 11.7 KV Metering Check

Refer to *section 10.3* for dual bushing display operation. For dual bushing controls sequentially check bushing “A” then “B”.

### 11.7.1 Direct Reading KV Check

The most accurate (and most dangerous) way to verify the KV readout accuracy is to connect a direct reading high voltage meter to the bus section and compare that reading with the KV display.

**! WARNING**

**Do not attempt this type of measurement unless you have the proper equipment and safety training.**

Turn off the MVC-IV and open the main circuit breaker. Ground the T-R set high voltage bushings. Connect the high voltage meter to the T-R set high voltage bushing. Unground the high voltage bushings and turn on the main circuit breaker.

Restart the MVC-IV. For bushing “B” verification, press the **Up** key to select bushing “B” in the KV readout.

Use the Conduction Angle adjustment (*see section 9.16*) to manually set stable operation just below the spark threshold. Verify that the **T-R Secondary KV** digital readout agrees with the high voltage meter within 5% of T-R nameplate KV rating.

If the error exceeds 5% of T-R nameplate KV, there is an error in the KV divider size setting (*see section 8.4*), a wiring error or one of the circuit boards is defective. Correct the problem before proceeding.

Shut off the T-R set and open the main breaker. Ground the T-R set high voltage bushings, remove the KV meter, remove the high voltage bushing grounds and reassemble all safety access covers before re-energizing the T-R set.

### 11.7.2 Calculated KV Check

The KV can be calculated and calibration verified using measurements taken at the **INTERFACE** board.

**! WARNING**

**600 Volts**

Apply power to the MVC-IV. Use the Conduction Angle adjustment (*see section 9.16*) to set stable operation just below the spark threshold. Select the desired bushing in the KV display.

Measure the DC voltage  $V_{IN}$  between terminals *J6-5 and J6-7* for KV<sub>a</sub> and between *J5-5 and J5-7* for KV<sub>b</sub>.

The equivalent KV is calculated as:

$$KV = \frac{V_{IN} \times R_{DIV}}{1.500}$$

Where: KV is secondary voltage in **kilovolts**  
 $R_{DIV}$  is the KV divider in **megohms**  
 $V_{IN}$  is input voltage in **volts**

Following is a sample calculation.

Assume:  
 $R_{DIV} = 160$  megohms  
 $V_{IN} = 0.411$  volts

Then:  
 $KV = (0.411 \times 160) / 1.500 = 43.84$  KV

Verify that the **T-R Secondary KV** digital readout agrees with the calculated value within 5% of KV Over Limit setting. If the error exceeds 5%, there is an error in the KV divider size setting (*see section 8.4*) or there is a wiring error or one of the circuit boards is defective. Correct the problem before proceeding.





# MVC IV VOLTAGE CONTROL MANUAL

NEUNDORFER PRECIPITATOR KNOWLEDGE



## 11.8 Final Checks

After verifying T-R metering accuracy, set the Primary and Secondary Current and Voltage Limits to the T-R set's maximum ratings. Some T-R sets have more than one primary circuit connection tap. Be sure to follow the Primary Current and Voltage nameplate rating for the tap in use.

### CAUTION

**If any primary circuit element; SCR, CLR, contactor, circuit breaker, fuses, or wiring has a lower current rating than the T-R set, the lowest current rated element in the primary circuit must be used for the Primary Current Limit setting.**

Use the Conduction Angle adjustment to increase the power levels as high as possible without sparking and recheck primary and secondary current and voltage metering accuracy.

Set Rap Limit, Spark Rate, Setback, Spark Response Mode, Back Corona and IE settings as desired. Set the Conduction Angle Limit to 160 degrees for fully automatic operation and the MVC-IV is ready for final checkout.

### WARNING

**DO NOT USE A FLOATED SCOPE. A FLOATED SCOPE IS POTENTIALLY LETHAL!**

### WARNING

**600 Volts**

Use the POS Digital Storage Oscilloscope function or connect a storage oscilloscope to the secondary current test points on the LOGIC PCB at test point TP63 with the ground lead on ground jumper JP2, or connect the scope probe to TP62 with the ground lead on TP61. Verify proper spark detection and quenching as shown in *figure 4*. Any restrikes will cause the quench time to extend as shown in *figure 5*.

Use the POS Digital Storage Oscilloscope function or connect an oscilloscope directly across the primary current metering CT. With the MVC-IV running at full conduction angle, verify that the primary current waveform conduction periods are sinusoidal with a 0.5 msec. minimum off time between half cycles and without appreciable distortion as shown in *figure 6*. If necessary reduce the Conduction Angle Limit setpoint to achieve an undistorted waveform with a 0.5 msec. minimum off time between half cycles.

*Figure 7* shows SCR gate to cathode oscilloscope waveforms at two different sweep speeds. The basic waveform is a fast rise pulse to 5 to 6 volts, decaying in about 25 – 30 usec to 1.6 volts followed by an off time of 95 – 100 usec. This waveform is repeated in a burst starting at the SCR turn on moment and lasts for up to 2.6 msec or until the next line zero cross event. *Figure 7a* shows the burst of 1 – 20 pulses that occurs each half cycle of the line. *Figure 7b* shows the details of the individual pulses.



# MVC IV VOLTAGE CONTROL MANUAL

NEUNDORFER PRECIPITATOR KNOWLEDGE

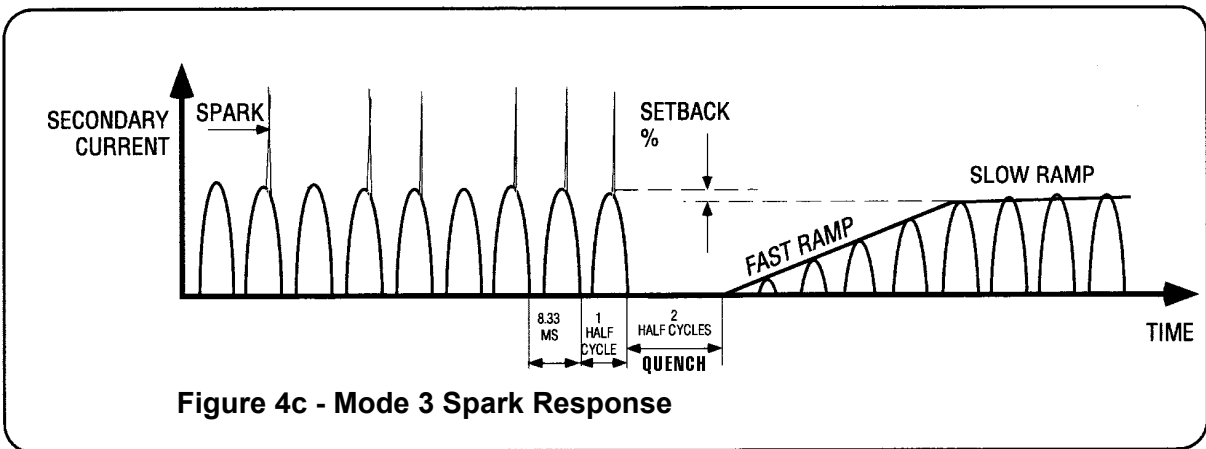
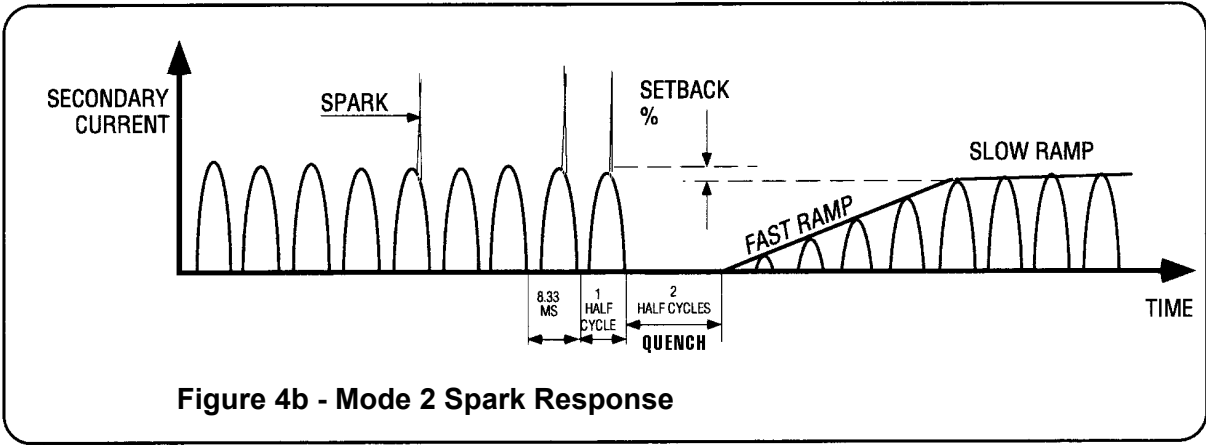
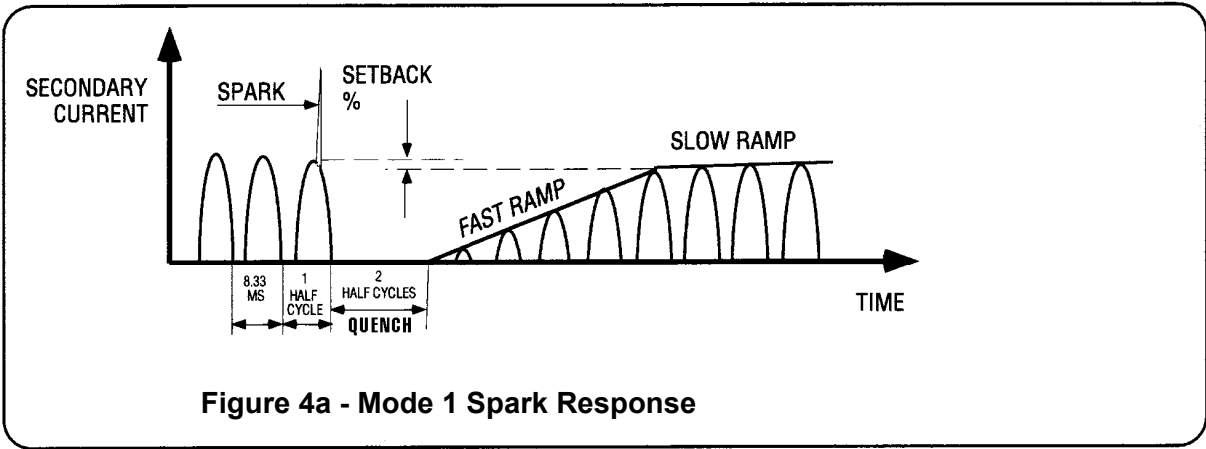

Figure 4 - Spark Response Mode Waveforms



# MVC IV VOLTAGE CONTROL MANUAL

NEUNDORFER PRECIPITATOR KNOWLEDGE

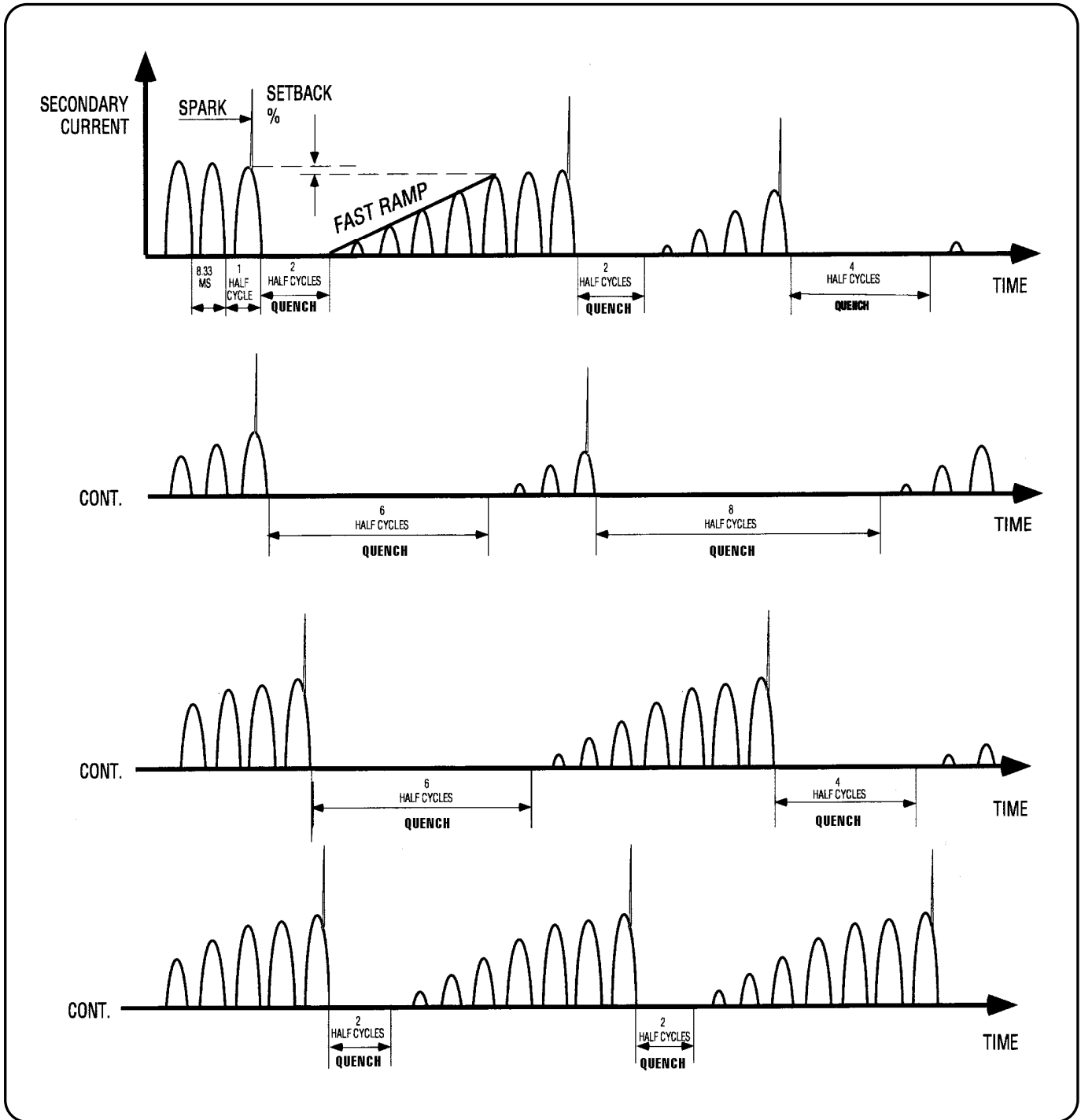
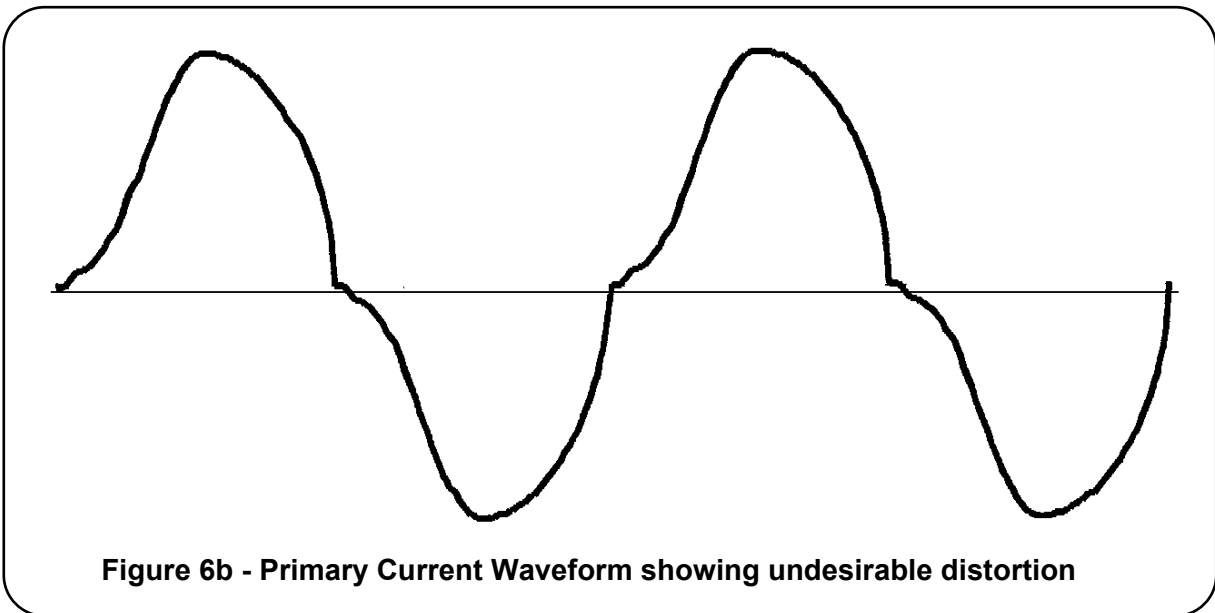
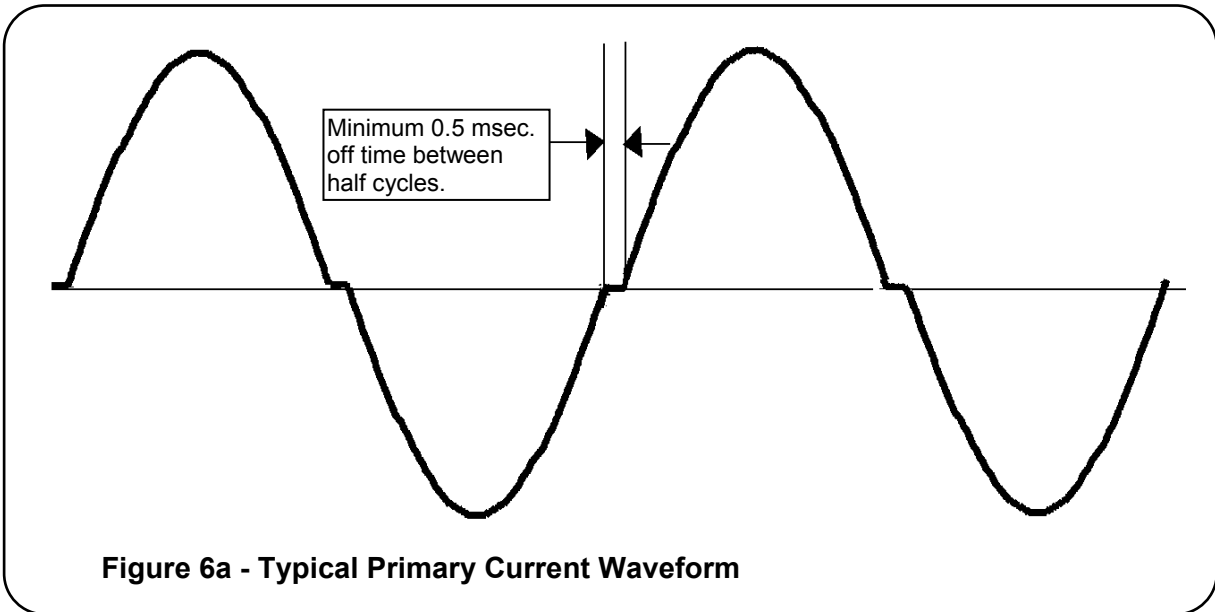

Figure 5 - Auto Spark Quench Interval Waveforms



**Figure 6 - Primary Current Waveforms**



# MVC IV VOLTAGE CONTROL MANUAL

NEUNDORFER PRECIPITATOR KNOWLEDGE

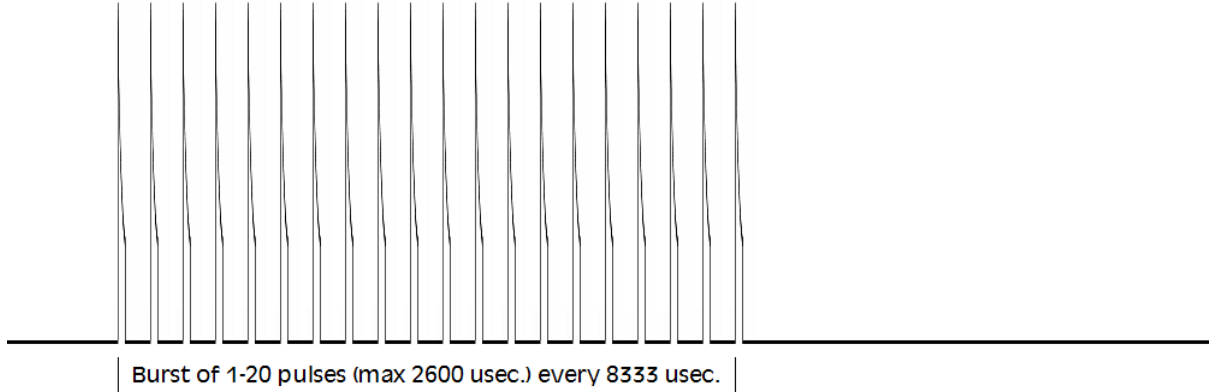

Figure 7a - SCR Gate to Cathode Waveform burst

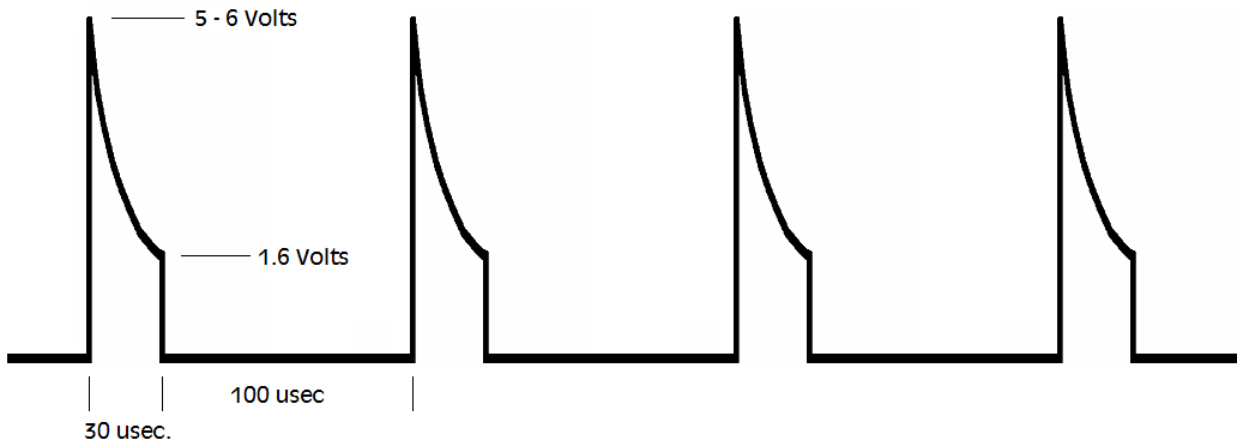

Figure 7b - SCR Gate to Cathode Signal Waveform detail

## Figure 7 - SCR Gate to Cathode Waveforms



# MVC IV VOLTAGE CONTROL MANUAL

NEUNDORFER PRECIPITATOR KNOWLEDGE



## 12.0 OPERATING SETUP

### 12.1 Suggested MVC-IV Setup

Table 15 lists the adjustable MVC-IV operating parameters along with the applicable section in the manual that covers each one.

Table 15, items 1 - 5 provide operational limits for the MVC-IV to prevent over stressing the T-R set and primary circuit elements. They should have been set following the guidelines in section 11.8.

If the nameplate shows different KV ratings for the different primary taps, it is safe to set the Secondary Over Voltage Limit to the highest rated tap even if that is not the tap in use. Some T-R sets have a peak KV rating that is significantly higher than the average KV rating. In that case, use the lower average DC KV rating as the KV Limit.

Item No.	Item	Manual Section
1	Primary Current Limit	9.1
2	Primary Over Voltage Limit	9.2
3	Secondary Current Limit	9.4
4	Secondary Over Voltage Limit	9.6
5	Conduction Angle Limit	9.16
6	Primary Low Voltage Limit	9.3
7	KVa Low Limit / Enable	9.7
8	KVb Low Limit / Enable	9.8
9	Rap Limit	9.5
10	Data Link Unit Number	9.18
11	POS Access Enable	9.19
12	Baseline Spark Rate	9.9
13	Setback	9.10
14	Spark Response Mode	9.11
15	Back Corona Software	9.12
16	IE Ratio Settings	9.13
17	AutoMax	9.14
18	Temperature	9.17

Table 15 - MVC-IV Adjustable Parameters

The Conduction Angle Limit is normally set to 160 degrees for automatic operation. There are some cases where poorly matched T-R set and CLR makes a lower setting necessary. See section 11.8.

The under voltage limits (Table 15, items 6 - 8) are used to detect a short in the precipitator bus section, which usually causes T-R set operation at current limit and low primary and secondary voltage. In this case, the MVC-IV will trip off due to low primary or secondary voltage. An under voltage trip is usually caused by a broken discharge wire or defective insulators. A typical setting for the Primary Under Voltage Limit is 100 Volts. The Secondary Under Voltage Limit is usually set well below the corona onset voltage, which is in the range of 10 KV - 20 KV depending on precipitator geometry.

KVa and KVb low Limits are also used as the means to enable / disable KV monitoring on the bushing. To disable a KV input, set the Low Limit to 0.00 (OFF). KV inputs with no signal must be disabled to prevent unwanted under voltage trips.

The Rap Limit need only be adjusted if the Reduced Power Rapping feature will be used. Reduced Power Rapping (RPR) or Power Off Rapping (POR) is sometimes useful to help dislodge collected dust from the plates. The RPR function is invoked via an opto coupler input or data link command to set the T-R secondary current down to the Rap Limit value. Setting the Rap Limit to zero provides POR. In some cases setting a low RPR value such as 10% of normal operating current will enhance rapping while still providing enough residual electric field to prevent unacceptable opacity spiking. The ideal setting is site specific and can only be determined by experimentation.

The Data Link Unit Number must be set to agree with the site specific documentation for the POS installation. If there is no POS, set the Data Link Unit Numbers sequentially. On automatic recovery from power failure, control startup is slightly staggered based on Data Link Unit Number to reduce power bus inrush load. See section 9.19 for setting the POS access level, Table 15, item 11.





# MVC IV VOLTAGE CONTROL MANUAL

NEUNDORFER PRECIPITATOR KNOWLEDGE



## 12.1 Suggested MVC-IV Setup (con't)

Table 15, items 12 - 16 are site specific, but we can provide some basic guidelines. As adjustments are made, observe the effect on the KV of the control being adjusted and the effect on KW or secondary current of the following field. Also observe any changes in opacity. Adjustments that increase KV for the field being adjusted, increase KW or secondary current of the following field, or reduce opacity are beneficial. Opposite changes suggest a decrease in collection.

Baseline Spark Rate is process and field dependent. The general pattern is to set higher spark rates toward the inlet of the precipitator. For a power plant or other process producing a rather stable gas stream, typical inlet spark rates would be 60 - 80 SPM decreasing to 10 - 20 SPM at the outlet. Other unstable processes such as BOP/BOF, paper mills, cement plants, lime kilns, or waste burners may require much higher spark rates to track a rapidly changing spark over voltage. In some rare cases spark rates of several hundred SPM are required for maximum collection.

In general, if raising the Spark Rate increases KV for the control being adjusted or increases KW or secondary current of the following field T-R set, or reduces opacity, use the higher Spark Rate otherwise use a lower rate.

Post Spark Setback affects the controller's stability and ability to track changes in spark over voltage. A setting of 5% to 10% is a good starting point and works well in most situations. Like Spark Rates, higher settings may be beneficial toward the inlet of the precipitator while lower ones may be acceptable toward the outlet. If raising the Setback provides more uniform spark rate or higher KV without a loss in following field power or increase in opacity, use the higher Setback.

To maintain stability, different setback percentage is usually required at lower power levels than at higher levels. The MVC-IV setback algorithm compensates the setback as power levels changes.

Spark Response Mode is set to 1 for most applications. Certain processes can produce a significant number of low intensity spit sparks that will self extinguish. These sparks generally occur late in the current waveform half cycle. Use the POS Digital Storage Oscilloscope function or a storage oscilloscope to observe the secondary current waveform. If spit sparking is observed, change the Spark Response Mode to number 2. If, with the MVC-IV set to Spark Response Mode 2, the oscilloscope shows a significant number of sparks that last only one half cycle, Mode 2 is probably beneficial. Mode 2 can also be useful when running Intermittent Energization with an "On" time setting of one half cycle. Mode 3 may be useful in cases of very low intensity sparking or when running IE with two half cycles of "On" time. Using a higher mode number setting often causes an increase in KW consumption which is usually interpreted as an indication of increased performance. The increase in KW, however, may be due only to the increased power dissipated in the longer lasting sparks and higher recharge currents.

Mode 4 may provide increased collection efficiency for certain spit spark situations. Refer to section 9.11 for more information on spark response modes.

If an increased mode number setting causes an increase in KV or increase in following field KW or decrease in opacity, it probably is beneficial. If an increased mode number causes the primary or secondary voltage for the control being adjusted to decrease, it is counterproductive and should not be used.

### CAUTION

Do not use modes 2 or 3 with a dual bushing T-R set operating in double half wave mode.



# MVC IV VOLTAGE CONTROL MANUAL

NEUNDORFER PRECIPITATOR KNOWLEDGE



## 12.1 Suggested MVC-IV Setup (con't)

Back Corona Control software is an algorithm designed to limit bus section operation below the back corona onset point. If it is unknown whether the bus section has back corona, run a manual V-I curve or use the automatic V-I curve function in POS to obtain a V-I curve. If the bus section has back corona, using the Back Corona software will usually decrease power consumption and increase collection. Refer to section 9.12 for more details on operation of the Back Corona software.

Intermittent Energization (IE) is another software algorithm designed to eliminate back corona and/or reduce energy consumption. IE rapidly cycles the T-R set primary power synchronous with the line voltage. Power is applied in 1, 2, or 3 half cycles of the line, then blocked for 2, 4, 6, 8, 10, 12 ... 62 half cycles. The repeated interruption of secondary current flow impedes the formation of back corona while usually reducing power consumption. In oversized precipitators without back corona, IE can often be used purely as an energy saving means.

### CAUTION

**Some T-R sets may not be compatible with the mechanical and electrical stresses generated by IE. If in doubt, check with the T-R set manufacturer before using IE.**

The optimum IE ratio is completely site specific and must be determined by experimentation. For best transformer balance, we suggest using one or three half cycles of “On” time for full wave T-R sets and one or two half cycles of “On” time for T-R sets operating in double half wave.

IE is locked out when the Spark Rate is set above 60 SPM or when Back Corona software is enabled. See section 9.13 for more information.

AutoMax, Table 15, item 17, is an algorithm to automatically adjust the MVC-IV control for maximum KV. *This feature is not yet implemented and is subject to change.*

The Temperature Alarm setting, Table 15, item 18, allows the user to set a cabinet temperature upper limit alarm point. A sensor on the LOGIC board senses local ambient temperature for display and sets an alarm point for recording by POS.



## 12.2 Normal Operation

Each time control power is applied to the MVC-IV or the **Reset** pushbutton switch is released, a self test is performed. If any errors are detected, the control will halt displaying an error code with all three decimal points lighted in the **Auxiliary Functions** digital readout. Refer to [section 15.1](#) for the meaning of any observed error codes. After the self test is complete, the control can be started by setting the optional door mounted **T-R On** switch to the on position or by pressing the **Start** key. The **T-R On** switch circuit must be closed for the keypad **On** button to function.

Under normal operating conditions the MVC-IV will operate automatically without the need for

periodic operator attention. The optional door mounted **T-R On** switch, keypad **Start** and **Stop** keys, or the **Remote Start**, **Remote Stop**, or **ACK Alarm** contact inputs are used to turn the T-R set high voltage on and off. If the MVC-IV is connected to a Neundorfer POS computer system or a DCS, data link commands can be used to stop, start, and reset the MVC-IV.

If during operation, the MVC-IV trips off or fails to operate properly, refer to the trouble shooting guides in [section 15](#) to identify probable causes of the problem.



## 13.0 DISPLAY PANEL USER MANUAL

The MVC-IV **DISPLAY** Panel is a microprocessor based device that communicates with the MVC-IV **LOGIC** board processor via a half duplex RS-485 serial interface at 76,800 baud using a proprietary protocol. Communications uses a master - slave protocol with the **DISPLAY** unit always the master.

A standard RJ-45 network cable supplies unregulated +22 volt power to the **DISPLAY** board and provides data in and data out communications. The **DISPLAY** unit connects directly to and receives power from a mating connector on the MVC-IV **LOGIC** board. A small power **SUPPLY / INTERFACE** board provides power and data link connections for remotely mounted displays.

### 13.1 Configurations

There are three possible configurations for the MVC-IV **DISPLAY** Panel.

- One MVC-IV **DISPLAY** **directly** connected to a single MVC-IV **LOGIC** board.
- One MVC-IV **DISPLAY** connected to more than one MVC-IV **LOGIC** board via a **Single Master LAN**.
- Two to 30 MVC-IV **DISPLAYS** connected to one or more MVC-IV **LOGIC** boards via a **Token Pass LAN**. *This is a planned feature for the MVC-IV **DISPLAY** and is not yet available.*

These configurations are determined by hardware and firmware. LAN enabled **DISPLAYS** have an additional status LED and digital display for Unit Number selection. In addition, **TOKEN PASS DISPLAYS** have special firmware implementing a token pass network among multiple **DISPLAY** panels. A **LAN ENABLE** micro jumper may be removed to force **LAN DISPLAY** hardware to function as a **DIRECT** connected display.

### 13.2 Display Operating Modes

**DIRECT** connected **DISPLAYS** have two operating modes. LAN enabled **DISPLAYS** add a third operating mode. Those modes are:

- Normal
- Security Access Functions
- Unit Select (LAN enabled displays only)

#### 13.2.1 Normal Mode

In Normal mode keys **9** and **0** are not used. All other keypad activity is passed to the target MVC-IV **LOGIC** processor and elicits a response back from the **LOGIC** processor providing status and operating data.

#### 13.2.2 Security Access Functions

With the display in Normal mode or Unit Select mode, pressing and releasing the **Access Code** key changes the display to Security Access Functions mode, awaiting entry of the security access code. See [section 13.3](#).

#### 13.2.3 Unit Select Mode (LAN enabled displays only)

With the display in Normal mode with security access enabled or disabled, pressing and releasing the **Unit Select** key changes the display to Unit Select mode, awaiting **LOGIC** processor unit number selection. See [section 13.5](#).



## 13.3 Security Access Code

**NOTE: Security Access Code is associated with the DISPLAY panel, not the MVC-IV control.** Security access enable, disable or re-programming activity will cancel Normal mode, but Normal mode may be active with security access either enabled or disabled.

### 13.3.1 Access Disabled Functionality:

- ACCESS LED is off.
- **Start, Stop, Set, Down,** and **Up** keys are disabled.  
Exceptions are:
  1. **Set** key will be allowed for parameters that require **Set** key to view setpoints.
  2. **Up & Down** will be allowed for KV bushing select function.
  3. **Start & Stop** will always be enabled for Direct Wired **DISPLAY** Panels.
- POS is allowed full control, if enabled. Security programming at POS will determine allowed functions.

### 13.3.2 Access Enabled functionality:

- ACCESS LED is on.
- All key switches are enabled to view, access and change MVC-IV control parameters. If access is via a **LAN DISPLAY**, the MVC-IV unit number assignment cannot be changed.
- POS keypad message will NOT be honored while a **DISPLAY** is talking to the **LOGIC**. (4 sec. time out)
- Security Access times out if there are no key hits for 4 minutes. The message, "**ACS d 15**" replaces the data in the **RESPONSE** and **AUX FUNCTIONS** displays for several seconds. The ACCESS LED turns off and access is disabled.

### 13.3.3 To Enable Access:

- Press and release **Access Code** key.
- Display blanks except **RESPONSE** and **AUXILIARY FUNCTIONS** displays change to all dashes, and **all keys function as numeric entry keys for the next 6 actuations.**
- Enter the security code using the keypad. Digits appear as entered in the **AUXILIARY FUNCTIONS** display, entering at the right and shifting toward the left and up to fill the **RESPONSE** and **AUXILIARY FUNCTIONS** display. There is no way to back up over an incorrect entry. Just finish entering any 6 digits to abort the entry process and start over.
- When the sixth digit is entered correctly, the ACCESS LED lights steady, the message, "**ACS EnA**" replaces the entered code for several seconds, and then the **DISPLAY** returns to normal. If there is an error in one or more digits, the process aborts after the sixth digit is entered, and the message, "**SEC Err**" replaces the entered code for several seconds, and then the **DISPLAY** returns to normal. Access remains disabled.

**Note: All units are shipped with the access code set to 000 000. Access code 000 000 defeats the security access system and will enable access at all times. Re-program the code to another value to use the Security Access feature. Do not lose the code, as there is no way short of re-programming the DISPLAY processor to enable access without the proper code.**

### 13.3.4 To Disable Access:

- While access is enabled, press and release the **Access Code** key. The message, "**ACS d 15**" replaces the data in the **RESPONSE** and **AUX FUNCTIONS** displays for several seconds. The ACCESS LED turns off and access is disabled.



## 13.3.5 To Re-program Access Code:

- Enable Access as explained above
- Press and hold the **Access Code** key.
- While holding the **Access Code** key, sequentially press and release the **Set** and **Up** keys.
- Release the **Access Code** key.
- The ACCESS LED flashes rapidly indicating programming mode.
- **DISPLAY** blanks except RESPONSE and AUXILIARY FUNCTIONS displays change to all dashes, and **all keys function as numeric entry keys for the next 6 actuations.**
- Enter the new security code using the keypad. Digits appear as entered in the AUXILIARY FUNCTIONS display, entering at the right and shifting toward the left and up to fill the RESPONSE and AUXILIARY FUNCTIONS display. There is no way to back up over an incorrect entry. Just finish entering 6 digits, abort the entry process, and start over.
- After entering the sixth digit, press the **SET (4)** key to store the new code, or press any key other than **SET** to abort the process. When the new security code is accepted, the message, "**SEC Ch**" replaces the entered code for several seconds. Then the **DISPLAY** returns to normal and the ACCESS LED lights steady. Access remains enabled.
- If the re-programming process is aborted by pressing any key other than **Set** after the sixth digit entry, the message, "**ACS Err**" replaces the entered code for several seconds. Then the **DISPLAY** returns to normal and the ACCESS LED lights steady. Access remains enabled.





## 13.4 POS Access

The Security Access Code functions as the Display Unit enable / disable, similar to the Local / Remote toggle switch on previous generation MVC's. Control of POS access to individual MVC-IV controls, is provided by a second cursor position related to the Data Link light. The second position sequences the Auxiliary Functions display between "OFF", "on" and "Err". "Err" gives POS full access. "on" allows POS to examine and retrieve data from the controls, but prevents POS from changing operating parameters. "OFF" blocks all POS access to the control.

## 13.5 LAN Display Unit Select:

Unit Select is a feature only of the DISPLAY panels arranged in a LAN network where one or more DISPLAY panels can access any MVC-IV control on the network. Unit select mode may be toggled on or off while security access is either enabled or disabled. Security access enable, disable or re-programming activity will cancel Unit Select mode.

- Toggle between Unit Select Mode active and inactive by repeat presses of the **Unit Select** key.

### 13.5.1 Unit Select Mode Inactive:

- UNIT SELECT LED is off.
- All key switches control and affect the MVC-IV controller designated by the UNIT NUMBER display as allowed by condition of ACCESS Enable / Disable.

### 13.5.2 Unit Select Mode Active:

- UNIT SELECT LED is on.
- Pressing the **Access Code** key with Unit Select Mode active will cancel Unit Select Mode and enter into Security Access Functions mode.

- The **Del (Hold)**, **Add (Set)**, **Down**, **Up**, **Last** and **Next** keys are redefined for Unit Select activity rather than affecting the MVC-IV control.
- **Down** and **Up** sequentially select the next lower or higher unit number. The selected unit number value appears in the UNIT NUMBER display, and the rest of the facepanel displays are updated to match the selected MVC-IV control. Selecting a non-existent or non-responding unit number blanks the DISPLAY, and provides the message, "LAN Err" in the RESPONSE and AUX FUNCTIONS displays.
- Pressing the **Next** and **Last** keys will move through the user's preferred list of controls in the forward or reverse order in which they were entered.

### 13.5.3 Making a Preferred Unit List:

- The **Hold (Del)**, **Set (Add)**, **Down**, and **Up** keys can be used to build the preferred access list for the **REMOTE DISPLAY** panel.
- Add or delete a unit number to the preferred list by pressing the **Set (Add)** or **Hold (Del)** key while the desired unit number is displayed with Unit Select Mode active.
- Use the **Last** or **Next** keys to navigate to the point in the preferred list where the new entry is to be deleted or inserted.
- Press **Hold (Del)**, to remove the selected controller unit number from the preferred list. The Unit Number display will change to "PPP" for several seconds to confirm removal of the selected item from the list.
- Use the **Down**, or **Up** keys to select a new unit number to add to the preferred list. Pressing the **Set (Add)** key will insert the new unit number in the list after the entry last accessed using the **Last** or **Next** keys. The Unit Number display will change to "PPP" for several seconds to confirm the selected item has been programmed into the list.



# MVC IV VOLTAGE CONTROL MANUAL

NEUNDORFER PRECIPITATOR KNOWLEDGE



## 13.6 Display Panel Power On Self Test:

During Display Test, the following keys have the listed action:

- **Hold** key will start / stop display test progress.
- **Next & Last** key will move display test manually when stopped.
- **Set** key will toggle between long and short display test. Display test type selection is remembered by **DISPLAY** panel for future power on startups.
- Short Display Test only performs test steps 1, 8 & 9 at power on.

Test Step	Display Condition
1	All Blank
2	Primary group - all 8's all LED's & DP's on
3	Secondary group - all 8's all LED's & DP's on
4	Response group all - 8's all LED's & DP's on
5	Aux Func. group - all 8's all LED's & DP's on
6	Status group - all LED's on
7	Unit Number - all 8's & all DP's on
8	<u>Firmware ID</u> in Primary & Secondary AMPS, <u>Setup Code</u> in Aux Functions
9	All Blank

### Firmware ID format

N V C 4 **D v . w x y z**

**D** = MVC-IV Display firmware

**v** = Program number

**w** = Major revision number

**x** = Minor revision alpha character

**y** = Communications type “-” or “n”, where:

“-” is for direct connect or single master

LAN firmware

“n” is for token pass Network firmware

**z** = Program assembly numerical configuration code

6 = 38,400 baud

8 = 76,800 baud

Setup Code is numerical code defining run time options. At present there are no run time options.

## 13.7 Display Processor Service Setup Mode:

**DISPLAY RESET** programming has provisions to check the FLASH checksum and automatically correct it if the New Program flag is true. There is a manual provision in case this fails. Coming out of RESET-PIN reset or POWER-ON reset with the **Set** and **Up** keys depressed will enter a Service Setup Mode, which will calculate and write the new FLASH checksum to EEPROM and halt with error code 0.0.0. in the AUX display. The next reset will restore operation.



# MVC IV VOLTAGE CONTROL MANUAL

NEUNDORFER PRECIPITATOR KNOWLEDGE



## 13.8 Token Pass Network Display User Setup Mode: *(planned feature, subject to change)*

Used to set Display Token Pass communications unit number for **DISPLAYS** with LAN hardware & Token Pass firmware only.

### 13.8.1 To Enter Display Setup Mode:

- Press the **Hold** key during the Power On Display Test.
- Press the **Next** key to advance to the final step (program ID & Token Pass unit number) of the display test. The Unit Number display will show the Token Pass LAN unit number for this **REMOTE DISPLAY** panel (not MVC-IV controller) in the UNIT NUMBER display. The Token Pass LAN Unit Number will be displayed as two digits without leading zero blanking and will be preceded by a dash to clearly differentiate it from MVC-IV CONTROLLER UNIT NUMBERS. Token Pass LAN Unit Numbers 1 through 31 display as -01 through -31. MVC-IV Controller Unit Numbers are displayed as 3 digits with leading zero blanking.
- Use the **Down** and **Up** keys to set the desired unit number.
- Press the **Set** key to save the new **LAN DISPLAY UNIT NUMBER**.

### 13.8.2 To Exit Display Setup Mode:

- Press **Hold** key at any time to exit DISPLAY SETUP MODE and finish Power On Display Test.

## 13.9 Setting MVC-IV LOGIC PROCESSOR UNIT NUMBER

**LOGIC Processor Data Link Unit Number changes can only be made using a direct connected display.**

Direct connected displays always communicate as unit number \$FF to controller unit number \$FF, and controllers accessed as unit \$FF always respond to direct wired display unit \$FF. A display processor is setup for direct connect operation by removing the LAN micro jumper on the display processor board.

With access enabled, use the **Next** or **Last** keys to access the UNIT NUMBER in the AUXILIARY FUNCTIONS display. Press the **Set** key. The DATA LINK LED will flash rapidly to indicate programming mode. Use the **Up** or **Down** keys to adjust the unit number and the **Set** key to program the new value into EEPROM.



# MVC IV VOLTAGE CONTROL MANUAL

NEUNDORFER PRECIPITATOR KNOWLEDGE



## 14.0 PCB JUMPERS, LED'S, TEST POINTS, SWITCHES and CONNECTORS

### 14.1 Table 16 - Logic Board Component Identification *(refer to figure 8)*

Logic Board Silk-screen	Item	Description
Ass'y No., Rev.	31	Assembly number and revision
Serial No.	32	Serial number
J8	1	<b>DISPLAY</b> RS-485 LAN IN connector
J9	2	<b>DISPLAY</b> RS-485 LAN OUT connector
J10	3	RJ-45 local <b>DISPLAY</b> RS-485 and power connector
J11	4	POS RS-485 LAN OUT connector
J12	5	POS RS-485 LAN IN connector
J31	25	Programming & diagnostic connector
P1	42	Signal connector from Interface board & test points
SW31 (RESET PUSHBUTTON)	26	Pushbutton switch, resets microprocessor.
CR12 (ZC)	41	LED, indicates 120VAC Zero Cross reference is present.
CR91 (RUN REQ)	34	LED, indicates Run Request 120 V input signal active.
CR92 (PERMISSIVE)	35	LED, indicates Permissive circuit closed.
CR93 (EXTERNAL TRIP)	36	LED, indicates External Trip 120 V input signal active.
CR94 (REMOTE STOP)	37	LED, indicates Remote Stop 120 V input signal active.
CR95 (REMOTE START)	38	LED, indicates Remote Start 120 V input signal active.
CR96 (ACK ALARM)	39	LED, indicates Ack Alarm (Reset) 120 V input signal active.
CR97 (RPR)	40	LED, indicates Reduced Power Rapping 120 V input signal active.
CR103 (DISPLAY RELAY)	33	LED, indicates <b>DISPLAY</b> RS-485 com relay energized.
CR113 (POS RELAY)	11	LED, indicates POS RS-485 com relay energized.
CR131 (K3 RELAY)	22	LED, indicates K3 (Trip Breaker) relay energized.
CR132 (K2 RELAY)	23	LED, indicates K2 (Trip Alarm) relay energized.
CR133 (K1 RELAY)	24	LED, indicates K1 (Run Enable) relay energized.
JP1	27	+5 volt test point
JP2	28	Power supply common (not earth ground) test point
JP4	29	+22 volt bus test point
TP11	30	-5 volt test point
TP21	21	+2.4 volt reference test point
TP22	20	+1.9 volt reference test point
TP23	19	+0.5 volt reference test point
TP43	12	Normalized primary current referenced to TP21
TP53	10	Normalized primary voltage referenced to TP22
TP63	14	Normalized secondary current referenced to TP23
TP64	13	Normalized secondary spark signal referenced to TP23
TP73	17	Normalized secondary voltage - "A" referenced to TP23
TP83	18	Normalized secondary voltage - "B" referenced to TP23
JP71	15	Secondary voltage - bushing "A" input 3 Hz filter
JP81	16	Secondary voltage - bushing "B" input 3 Hz filter
JP102 & JP103	6,7	<b>DISPLAY</b> RS-485 LAN terminator activation jumpers
JP111 & JP112	8,9	POS RS-485 LAN terminator activation jumpers





# MVC IV VOLTAGE CONTROL MANUAL

NEUNDORFER PRECIPITATOR KNOWLEDGE



## 14.2 Table 17 - Interface Board Component Identification *(refer to figure 9)*

Interface Board Silk-screen	Item	Description
Ass'y No., Rev.	9	Assembly number and revision
Serial No.	10	Serial number
F1	1	Fuse, 120 VAC LOGIC system power, user replaceable
CR12	12	LED, indicates unregulated +22 volt DC power supply is operational.
J1	2	Connector, 120 VAC & Ground inputs
J2	3	Connector, 120 VAC Relay outputs
J3	4	Connector, Opto coupler inputs
J4	5	Connector, Opto coupler inputs, 120 VAC control wiring
J5	6	Connector, Primary Current, KVb feedback
J6	7	Connector, Secondary Current, KVa feedback
J7	11	Connector, Primary Voltage feedback and SCR gate output
J8	8	Signal connector to LOGIC board





# MVC IV VOLTAGE CONTROL MANUAL

NEUNDORFER PRECIPITATOR KNOWLEDGE

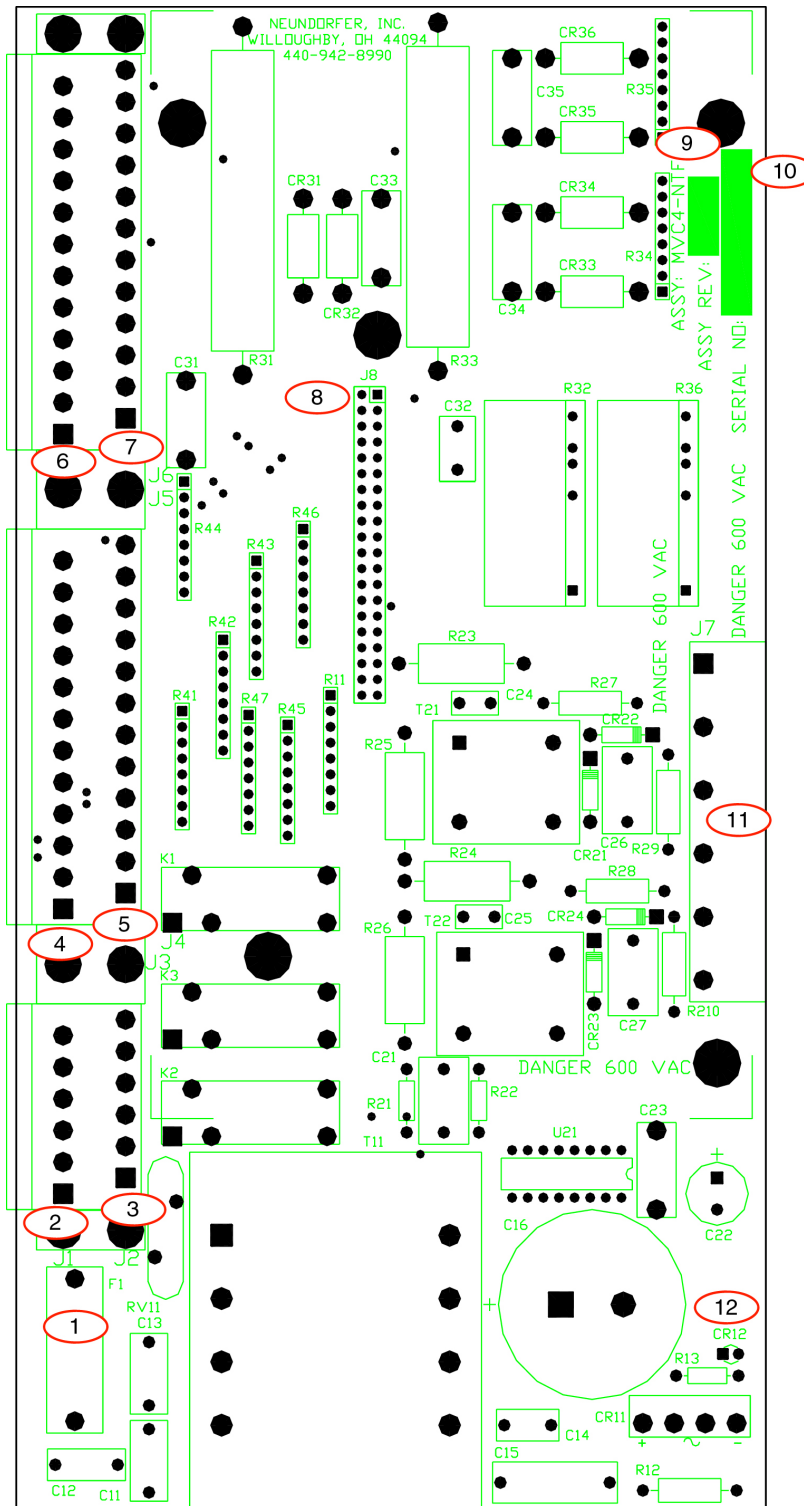

Figure 9 - MVC-IV Interface Board Component Identification



# MVC IV VOLTAGE CONTROL MANUAL

NEUNDORFER PRECIPITATOR KNOWLEDGE



## 14.3 Table 18 - Display Board Component Identification (refer to figure 10)

Display Board Silk-screen	Item	Description
Ass'y No., Rev.	9	Assembly number and revision
Serial No.	10	Serial number
RS1 (RESET PUSHBUTTON)	3	Pushbutton switch, resets microprocessor.
J1	5	RJ-45 connector, <b>DISPLAY</b> RS-485 data and power
J2	1	Programming & diagnostic connector
JP1	8	+5 volt test point
JP2	6	Power supply common (not earth ground) test point
JP3	4	Jumper, <b>REMOTE DISPLAY LAN</b> configuration enable
JP4, JP5	7	+22 volt test point
JP6	2	Micro Jumper, connects J2 pin 7 to pin 8 to enable RS1

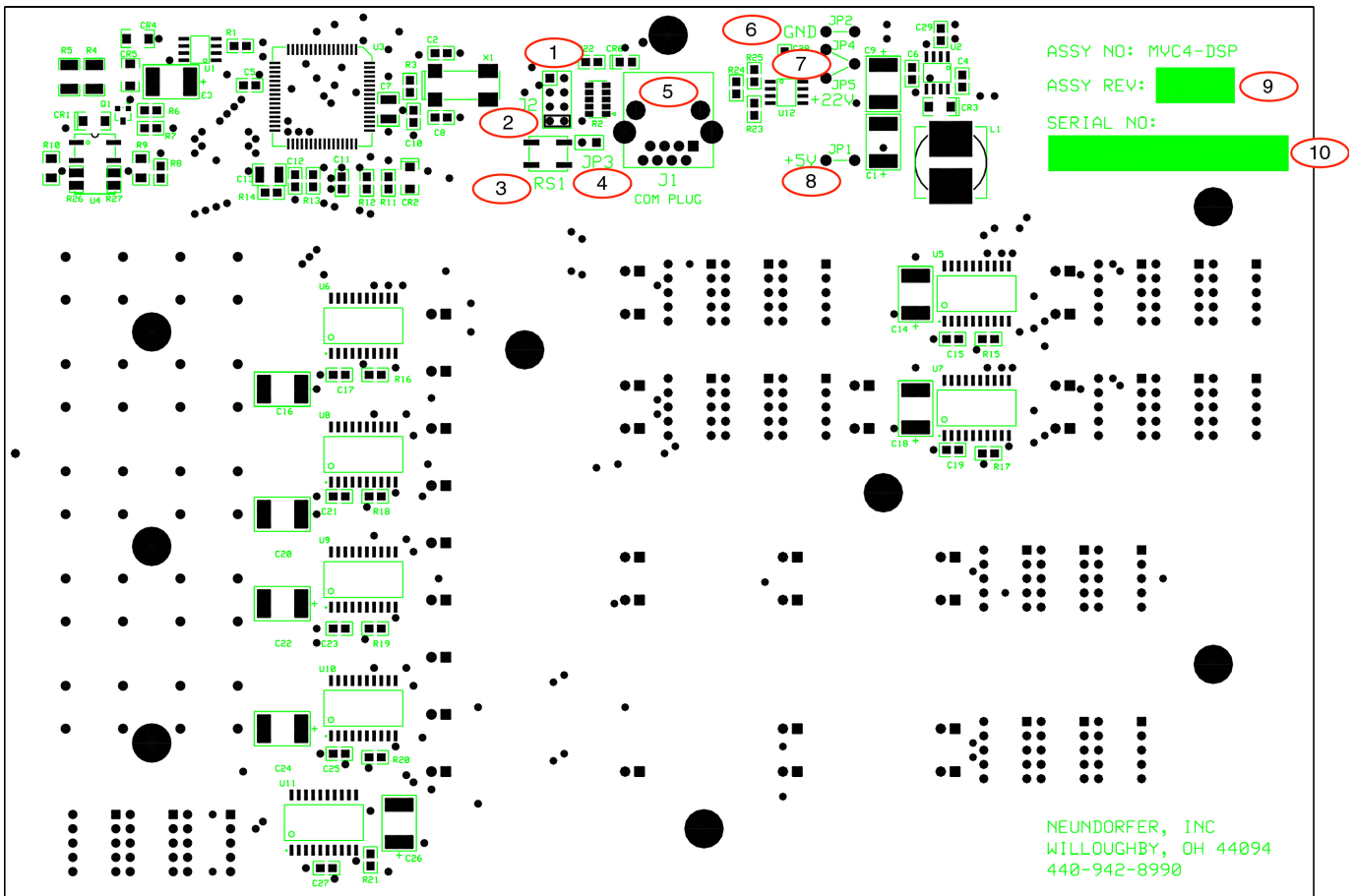

Figure 10 - MVC-IV Display Board Component Identification



# MVC IV VOLTAGE CONTROL MANUAL

NEUNDORFER PRECIPITATOR KNOWLEDGE



This page intentionally blank.



# MVC IV VOLTAGE CONTROL MANUAL

NEUNDORFER PRECIPITATOR KNOWLEDGE



## 15.0 TROUBLE SHOOTING

### 15.1 Diagnostic Error Codes

Certain system errors and subsystem malfunctions can be detected by the **DISPLAY** and **LOGIC** processors. If this happens, an error code will be displayed in the **Auxiliary Functions** digital readout. Error codes are easily recognized as they are displayed with all three decimal points lighted. Many of these codes indicate an internal microcomputer failure, but several point to external problems that may be customer correctable. **LOGIC** processor faults cause the controller to shut down, while **DISPLAY** processor faults provide a

diagnostic code display but allow the control to continue running. Transient error codes during controller or display boot up are normal while a diagnostic test is being performed and can be ignored.

The error codes and possible causes are listed in *tables 18 and 19* followed by a diagnostic code trouble shooting guide, *Table 21*. When calling Neundorfer for assistance be sure to note any observed error codes.

Error Code	Cause
0.0.0. - 0.3.3.	Internal processor error
0.3.4. - 0.3.9.	Unused
0.4.0.	Internal processor error (RAM Test error)
0.4.1.	Internal processor error (FLASH test error)
0.4.2.	Internal processor error (EEPROM test error)
0.4.3.	Internal processor error (EEPROM stuck busy)
0.4.4.	Unused
0.4.5.	Display UART receiver Overrun error ( <i>see section 15.1.9</i> )
0.4.6.	Display UART receiver Framing error ( <i>see section 15.1.9</i> )
0.4.7.	Display UART receiver FIFO Overflow error ( <i>see section 15.1.9</i> )

**Table 19 - Display Processor Diagnostic Error Codes**



# MVC IV VOLTAGE CONTROL MANUAL

NEUNDORFER PRECIPITATOR KNOWLEDGE



Error Code	Cause
0.6.8. - 0.9.6.	Internal processor errors
0.9.7.	Unused
0.9.8. - 1.0.7.	Internal processor errors
1.0.8. - 1.1.2.	Unused
1.1.3. - 1.1.5.	Internal processor errors
1.1.6.	Unused
1.1.7.	Internal processor error
1.1.8.	Unused
1.1.9.	Internal processor error
1.2.0.	Unused
1.2.1.	Internal processor error
1.2.2. - 1.2.3.	Unused
1.2.4. - 1.2.8.	Internal processor errors
1.2.9.	Loss of Zero Cross signal ( <i>see section 15.1.3</i> )
1.3.0.	Internal processor error (CPU clock failure)
1.3.1.	Internal processor error (FLASH test error) ( <i>see section 15.1.4</i> )
1.3.2.	Internal processor error (RAM test error)
1.3.3.	Internal processor error (EEPROM test error) ( <i>see section 15.1.5</i> )
1.3.4.	Primary Current Limit out of range for CT Size ( <i>see section 15.1.6</i> )
1.3.5.	Secondary Current Limit above Max Range ( <i>see section 15.1.7</i> )
1.3.6.	Incorrect CPU crystal frequency or incorrect line frequency ( <i>see section 15.1.8</i> )
1.3.7.	POS UART receiver Overrun error ( <i>see section 15.1.9</i> )
1.3.8.	POS UART receiver Framing error ( <i>see section 15.1.9</i> )
1.3.9.	Internal processor error (POS UART FIFO buffer overflow error) ( <i>see section 15.1.9</i> )
1.4.0.	Internal processor error (Incorrect MASK register)
1.4.1.	MVC-IV powered up with Permissive True ( <i>see section 15.1.10</i> )
1.4.2.	Internal processor error (Invalid Spark Sensitivity) ( <i>see section 15.1.11</i> )
1.4.3.	Internal processor error (EEPROM stuck busy)
1.4.4.	Internal processor error (FLASH stuck busy)
1.4.5.	Unused
1.4.6.	Internal processor error (SPI-0 failure)
1.4.7.	Display UART receiver Overrun error ( <i>see section 15.1.9</i> )
1.4.8.	Display UART receiver Framing error ( <i>see section 15.1.9</i> )
1.4.9.	Internal processor error (Display UART FIFO overflow error) ( <i>see section 15.1.9</i> )
1.5.0.	Unused
1.5.1. - 1.5.3.	Internal processor errors (AD converter 0 errors) ( <i>see section 15.1.12</i> )
1.5.4. - 1.6.0.	Unused
1.6.1. - 1.6.3.	Internal processor errors (AD converter 1 errors) ( <i>see section 15.1.12</i> )
1.6.4. - 1.9.9.	Unused
H.L.P.	T-R run away ( <i>see section 15.1.13</i> )

Table 20 - Logic Processor Diagnostic Error Codes



# MVC IV VOLTAGE CONTROL MANUAL

NEUNDORFER PRECIPITATOR KNOWLEDGE



ITEM	PROBLEM	CAUSE	SOLUTION
15.1.1	Occasional error codes designated “internal error” or random unexplained trips, controller lockup or reboot.	<ol style="list-style-type: none"> <li>1. Improper controller grounding inside AVC cabinet.</li> <li>2. Improper SCR Gate signal wiring or lay.</li> <li>3. High Voltage interference.</li> <li>4. Defective or missing SCR snubber circuit.</li> </ol>	<ol style="list-style-type: none"> <li>1. Verify proper grounding per <a href="#">section 5.3</a>.</li> <li>2. Use twisted pair dressed away from Logic board per <a href="#">sections 1.3 &amp; 5.5</a>.</li> <li>3a. Check KV divider for HV breakdown.</li> <li>3b. Verify proper isolation between HV and T-R primary and feedback wiring.</li> <li>4. Replace SCR snubber network with Neundorfer design.</li> </ol>
15.1.2	Control powers up with an “internal error” code	<ol style="list-style-type: none"> <li>1. Defective Microcontroller.</li> </ol>	<ol style="list-style-type: none"> <li>1. Replace <b>LOGIC</b> board</li> </ol>
15.1.3	Error code 1.2.9.	<ol style="list-style-type: none"> <li>1. Loss of Zero Cross signal</li> </ol>	<ol style="list-style-type: none"> <li>1. Replace <b>LOGIC</b> board</li> <li>2. Replace <b>INTERFACE</b> board</li> </ol>
15.1.4	Error code 1.3.1.	<ol style="list-style-type: none"> <li>1. If a new program has been loaded into memory.</li> <li>2. Defective Microcontroller.</li> </ol>	<ol style="list-style-type: none"> <li>1. Follow directions in <a href="#">section 3.3</a> to correct this error.</li> <li>2. Replace <b>LOGIC</b> board.</li> </ol>
15.1.5	Error code 1.3.3.	<ol style="list-style-type: none"> <li>1. If a new program has been loaded into memory.</li> <li>2. Defective Microcontroller.</li> </ol>	<ol style="list-style-type: none"> <li>1. Follow directions in <a href="#">section 3.3</a> to correct this error.</li> <li>2. Replace <b>LOGIC</b> board.</li> </ol>
15.1.6	Error code 1.3.4.	<ol style="list-style-type: none"> <li>1. Primary Current limit is not valid for specified CT value.</li> <li>2. <b>LOGIC</b> CPU failure.</li> </ol>	<ol style="list-style-type: none"> <li>1. See <a href="#">sections 8.2 and 9.1</a> for setting the correct CT and Primary Current Limit values.</li> <li>2. Replace <b>LOGIC</b> board.</li> </ol>
15.1.7	Error code 1.3.5.	<ol style="list-style-type: none"> <li>1. Secondary Current Limit is set higher than Max limit.</li> <li>2. <b>LOGIC</b> CPU failure.</li> </ol>	<ol style="list-style-type: none"> <li>1. Referring to <a href="#">section 8.3</a> set the Max Secondary Current Limit to 3.20. Then go to normal operating mode and, referring to <a href="#">section 9.4</a>, adjust Secondary Current Limit as desired. Return to System Setup Mode (<a href="#">section 8.3</a>) and set Max Secondary Current Limit to T-R nameplate rating.</li> <li>2. Replace <b>LOGIC</b> board.</li> </ol>
15.1.8	Error code 1.3.6.	<ol style="list-style-type: none"> <li>1. Power line frequency differs more than 1% from 60 Hz. or is severely distorted.</li> <li>2. <b>LOGIC</b> CPU crystal frequency is off by more than 1%.</li> </ol>	<ol style="list-style-type: none"> <li>1. Correct power bus problem.</li> <li>2. Replace <b>LOGIC</b> board.</li> </ol>
15.1.9	Error codes 0.4.5. - 0.4.7. Error codes 1.3.7. - 1.3.9. Error codes 1.4.7. - 1.4.9.	<ol style="list-style-type: none"> <li>1. Excessive electrical noise on data link.</li> <li>2. High electrical noise level inside AVC cabinet.</li> <li>3. Defective or missing SCR snubber circuit.</li> </ol>	<ol style="list-style-type: none"> <li>1a. Verify proper data line termination.</li> <li>1b. Verify proper data line wiring.</li> <li>1c. Verify data line shield is not grounded at multiple points.</li> <li>2. Verify proper grounding per <a href="#">section 5.3</a>.</li> <li>3. Replace SCR snubber network with Neundorfer design.</li> </ol>

**Table 21 - Diagnostic Code Trouble Shooting Guide (con't next page)**





# MVC IV VOLTAGE CONTROL MANUAL

NEUNDORFER PRECIPITATOR KNOWLEDGE



ITEM	PROBLEM	CAUSE	SOLUTION
15.1.10	Error code 1.4.1. Indicates contactor closed when power applied to logic system.	<ol style="list-style-type: none"> <li>1. Wiring error can cause false indication.</li> <li>2. Contactor stuck close with no power at coil.</li> <li>3. Contactor coil always has power on it.</li> <li>4. Contactor open, but auxiliary contacts stuck closed.</li> <li>5. Contactor open and auxiliary contacts open.</li> </ol>	<ol style="list-style-type: none"> <li>1. Verify wiring against system drawings.</li> <li>2. Replace contactor.</li> <li>3a. Verify wiring against system drawings.</li> <li>3b. Replace <b>LOGIC</b> board.</li> <li>3c. Replace <b>INTERFACE</b> board.</li> <li>4. Replace auxiliary contacts.</li> <li>5a. Verify auxiliary contact wiring.</li> <li>5b. Replace <b>LOGIC</b> board.</li> <li>5c. Replace <b>INTERFACE</b> board.</li> </ol>
15.1.11	Error code 1.4.2.	<ol style="list-style-type: none"> <li>1. Invalid Spark Sensitivity.</li> <li>2. Failure of CPU.</li> </ol>	<ol style="list-style-type: none"> <li>1. Call Neundorfer for help.</li> <li>2. Replace <b>LOGIC</b> board.</li> </ol>
15.1.12	Error code 1.5.1. to 1.5.3. Error code 1.6.1. to 1.6.3.	<ol style="list-style-type: none"> <li>1. A/D converter fault.</li> </ol>	<ol style="list-style-type: none"> <li>1. Replace <b>LOGIC</b> board.</li> </ol>
15.1.13	Error code H.L.P.	<ol style="list-style-type: none"> <li>1. MVC-IV was unable to stop power flow to T-R after a trip.</li> </ol>	<ol style="list-style-type: none"> <li>1. Diagnose possible shorted SCR in system with no contactor.</li> </ol>
15.1.14	All other error codes.	<ol style="list-style-type: none"> <li>1. Failure of CPU.</li> </ol>	<ol style="list-style-type: none"> <li>1. Replace <b>LOGIC</b> board.</li> </ol>

**Table 21 (con't) - Diagnostic Code Trouble Shooting Guide**



# MVC IV VOLTAGE CONTROL MANUAL

NEUNDORFER PRECIPITATOR KNOWLEDGE



## 15.2 MVC-IV Trouble Shooting Guide

Table 22 provides a systematic approach to diagnosing MVC-IV operational problems. These are the kind of problems that are likely to occur at initial startup as a result of wiring problems or during operation as a result of component failure.

Find the entry in the following table that most closely describes the observed problem and follow the cause and solution suggestions.

Certain problems result in an error code being displayed in the **Auxiliary Functions** digital readout with all decimal points lighted. Attempt to resolve any error codes before following other failure symptoms. See [section 15.1](#).

Some possible causes listed include things like wiring errors that are only likely to occur on initial startup. Keep in mind if this is an initial startup problem, or a problem that has developed after the MVC-IV has been functioning properly.

ITEM	PROBLEM	CAUSE	SOLUTION
15.2.1	All LED indicators and readouts are dark.	<ol style="list-style-type: none"> <li>1. Main breaker off.</li> <li>2. Control transformer fuses cleared.</li> <li>3. Fuse F1 (<i>figure 9, item 1</i>) on <b>INTERFACE PCB</b> cleared.</li> </ol>	<ol style="list-style-type: none"> <li>1. Turn breaker on.</li> <li>2. Check primary and secondary fuses, replace if needed.</li> <li>3. Check F1 fuse (<i>figure 9, item 1</i>) on <b>INTERFACE PCB</b>.</li> </ol>
15.2.2	Control does not perform self test. No diagnostic codes observed.	<ol style="list-style-type: none"> <li>1. <b>LOGIC PCB</b> failure.</li> <li>2. <b>INTERFACE PCB</b> failure.</li> </ol>	<ol style="list-style-type: none"> <li>1. Replace <b>LOGIC</b> board.</li> <li>2. Replace <b>INTERFACE</b> board.</li> </ol>
15.2.3	Contactors will not close when <b>T-R On</b> switch closed. <b>External Trip</b> indication or <b>Permissive</b> flashing.	<ol style="list-style-type: none"> <li>1. Incorrect wiring to <b>T-R On</b> switch.</li> <li>2. Contactor coil defective.</li> <li>3. MVC-IV was stopped by data link command or Remote Stop.</li> <li>4. <b>Permissive Circuit</b> is not closed.</li> <li>5. <b>External Trip</b> signal is active.</li> <li>6. Failed current monitor relay (CMR).</li> <li>7. No power to contactor coil when T-R switch is closed.</li> </ol>	<ol style="list-style-type: none"> <li>1. Verify proper wiring.</li> <li>2. If 120 VAC at coil, replace coil.</li> <li>3. Restart by data link command or de-assert Remote Stop.</li> <li>4a. Determine and remedy cause of lost <b>Permissive</b>.</li> <li>4b. Install jumper on <b>INTERFACE PCB</b> from J1-5 to J1-6.</li> <li>5a. <b>External Trip</b> input is programmed wrong. See <a href="#">section 8.5</a> to correct.</li> <li>5b. Determine and remedy cause of <b>External Trip</b> signal.</li> <li>6. Replace CMR. If no CMR provided, install jumper on <b>INTERFACE PCB</b> from J4-1 to J4-2.</li> <li>7a. Verify correct system wiring.</li> <li>7b. Replace <b>LOGIC</b> board.</li> <li>7c. Replace <b>INTERFACE</b> board</li> </ol>

Table 22 - MVC-IV Operational Problem Trouble Shooting Guide (con't next page)



# MVC IV VOLTAGE CONTROL MANUAL

NEUNDORFER PRECIPITATOR KNOWLEDGE



ITEM	PROBLEM	CAUSE	SOLUTION
15.2.4	<b>External Trip</b> after one second, no over limit indicators.	<ol style="list-style-type: none"> <li><b>External Trip</b> signal is true.</li> <li><b>External Trip</b> signal is configured incorrectly.</li> </ol>	<ol style="list-style-type: none"> <li>Determine and remedy cause of <b>External Trip</b> signal.</li> <li><b>External Trip</b> input is programmed wrong. See <a href="#">section 8.5</a> to correct.</li> </ol>
15.2.5	<b>Trip</b> indicators will not go off when <b>T-R On</b> switch is opened or <b>Stop</b> key is pressed.	<ol style="list-style-type: none"> <li><b>External Trip</b> signal is true.</li> <li><b>T-R On</b> switch stuck closed.</li> <li>Failed <b>LOGIC</b> PCB.</li> <li><b>INTERFACE</b> PCB failure.</li> </ol>	<ol style="list-style-type: none"> <li>See <a href="#">Table 22, item 15.2.4</a> above</li> <li>Replace switch.</li> <li>Replace <b>LOGIC</b> PCB.</li> <li>Replace <b>INTERFACE</b> board.</li> </ol>
15.2.6	Kilowatt display reads zero or very low.	<ol style="list-style-type: none"> <li>Primary voltage and current inputs out of phase.</li> </ol>	<ol style="list-style-type: none"> <li>Reverse leads on primary current CT or at <b>INTERFACE</b> board <i>J5</i> terminals 1 &amp; 2.</li> </ol>
15.2.7	Primary voltage reads low and secondary voltage reads high at start-up or primary voltage reads high with shorted T-R set.	<ol style="list-style-type: none"> <li>Primary voltage sensing is wired across Current Limiting Reactor (CLR) and not across the primary of the T-R set.</li> </ol>	<ol style="list-style-type: none"> <li>Re-wire primary voltage sensing across T-R set as shown on wiring print.</li> </ol>
15.2.8	<b>T-R Secondary Amps</b> display reads zero.	<ol style="list-style-type: none"> <li>Polarity reversed on secondary current signal input at <b>INTERFACE</b> PCB <i>J6</i> pins 1 &amp; 2.</li> <li>No secondary current input signal.</li> <li><b>LOGIC</b> board failure.</li> <li><b>INTERFACE</b> PCB failure.</li> </ol>	<ol style="list-style-type: none"> <li><b>INTERFACE</b> PCB <i>J6-1</i> should be connected to positive side of T-R bridge and <i>J6-2</i> should be connected to the T-R set ground point.</li> <li>Check for signal between <i>J6-1</i> (positive) and <i>J6-2</i> (negative) on the <b>INTERFACE</b> circuit board with scope. Should be positive full wave rectified. If inverted, reverse wiring. If no signal, check wiring to T-R set and sensing resistor.</li> <li>Replace <b>LOGIC</b> PCB.</li> <li>Replace <b>INTERFACE</b> PCB.</li> </ol>
15.2.9	Control does not sense sparks.	<ol style="list-style-type: none"> <li>No secondary current signal.</li> </ol>	<ol style="list-style-type: none"> <li>See solution for previous symptom, “<b>T-R Secondary Amps</b> display reads zero” in <a href="#">section 15.2.8</a>.</li> </ol>
15.2.10	<b>T-R Secondary KV</b> display reads zero. Control trips on Under Voltage after 30 seconds.	<ol style="list-style-type: none"> <li>Polarity reversed on secondary KV signal.</li> <li>No secondary voltage input signal.</li> <li>Circuit Jumpers incorrect.</li> <li><b>LOGIC</b> PCB failure.</li> <li><b>INTERFACE</b> PCB failure.</li> </ol>	<ol style="list-style-type: none"> <li>Check bushing “A” signal at <b>INTERFACE</b> PCB <i>J6</i> terminal 5 relative to 7 and <i>J5</i> terminal 5 relative to 7 for bushing “B”. It should be a negative saw tooth waveform of -0.3 to -1.5 volts. <ol style="list-style-type: none"> <li>Check and correct wiring to and signal network and surge arrestors at divider.</li> <li>Verify the voltage divider still has the correct value.</li> <li>Disable KV monitoring for affected high voltage bushing. See <a href="#">section 9.7 &amp; 9.8</a>.</li> </ol> </li> <li>Verify correct wiring at <i>J6</i>, terminals 9-12 for KV<sub>a</sub> and <i>J5</i>, terminals 9-12 for KV<sub>b</sub>.</li> <li>Replace <b>LOGIC</b> PCB.</li> <li>Replace <b>INTERFACE</b> PCB.</li> </ol>

**Table 22 (con't) - MVC-IV Operational Problem Trouble Shooting Guide (con't next page)**



# MVC IV VOLTAGE CONTROL MANUAL

NEUNDORFER PRECIPITATOR KNOWLEDGE



ITEM	PROBLEM	CAUSE	SOLUTION
15.2.11	When <b>T-R On</b> switch is closed SCR's do not turn on, contactor closes.	<ol style="list-style-type: none"> <li>1. Auxiliary contacts on contactor are not closing or wired in.</li> <li>2. SCR Gate wiring may be reversed. If so, the SCR's may not turn on reliably.</li> <li>3. No 480 - 600 Volt power to SCR stack.</li> <li>4a. No firing pulses from the <b>INTERFACE PCB</b>.</li> <li>4b. Faulty SCR stack.</li> <li>5. <b>LOGIC</b> board failure.</li> </ol>	<ol style="list-style-type: none"> <li>1. Check auxiliary contacts on contactor.</li> <li>2. Check the wiring from the <b>INTERFACE PCB (GATE FIRING CIRCUIT)</b> to the SCR's.</li> <li>3. If no 480 - 600 VAC on output of contactor correct open circuit.</li> <li>4. Use a scope and check for firing pulses at <b>INTERFACE PCB J7</b> terminals 3 to 4 then 5 to 6. <b>WARNING, 600 Volts!</b> The signal is 6 volts peak to peak connected to the 600 volt line. See <i>figure 7</i> for SCR gate waveform. If good gate signal replace SCR stack. If no signal, look for shorted gate wiring or replace <b>INTERFACE</b> board.</li> <li>5. Replace <b>LOGIC PCB</b>.</li> </ol>
15.2.12	When <b>T-R On</b> switch is closed control goes into over current <i>about one second after contactor closes</i> and then trips off showing T-R primary or secondary <b>Over Limit</b> . It may be necessary to connect a scope to the primary current transformer to determine when current flow begins.	<ol style="list-style-type: none"> <li>1. Incorrect primary current transformer ratio setting.</li> <li>2. <b>LOGIC</b> is powered from different phase than T-R</li> <li>3. Zero Cross signal is lagging the line voltage.</li> <li>4. Failed current sensing input on <b>INTERFACE</b> board.</li> <li>5. <b>LOGIC</b> board failure.</li> </ol>	<ol style="list-style-type: none"> <li>1. See <i>section 8.2</i> for adjusting the correct CT ratio setting.</li> <li>2. Review and correct wiring.</li> <li>3. Replace <b>INTERFACE PCB</b>.</li> <li>4. Replace <b>INTERFACE PCB</b>.</li> <li>5. Replace <b>LOGIC PCB</b>.</li> </ol>

Table 22 (con't) - MVC-IV Operational Problem Trouble Shooting Guide (con't next page)



# MVC IV VOLTAGE CONTROL MANUAL

NEUNDORFER PRECIPITATOR KNOWLEDGE



ITEM	PROBLEM	CAUSE	SOLUTION
15.2.13	When <b>T-R On</b> switch is closed control goes into over current <i>the moment the contactor closes</i> and then trips off. It may be necessary to connect a scope to the primary CT to determine when current flow begins.	<ol style="list-style-type: none"> <li>The SCR stack is wired incorrectly.</li> <li>The SCR's are shorted.</li> <li>3a. Defective gate firing circuit.</li> <li>3b. Defective <b>LOGIC</b> board.</li> </ol>	<ol style="list-style-type: none"> <li>Check the cables attached to the SCR stack. One cable is the feed from the contactor. The other is the output to the CLR or T-R set. One cable connects to the rear heat sink the other cable connects to the front one.</li> <li>Disconnect both pairs of SCR gate leads from the <b>INTERFACE PCB (GATE FIRING CIRCUIT)</b> and short them together. Try to restart the control. If it trips on over current again, replace the SCR stack.</li> <li>If there is no current flow with SCR gates disconnected and shorted;</li> <li>3a. Replace the <b>INTERFACE PCB (GATE FIRING CIRCUIT)</b>.</li> <li>3b. Replace <b>LOGIC</b> board.</li> </ol>
15.2.14	T-R power levels remain at minimum with <b>Setback</b> and <b>Spark</b> indicators continuously lit. May trip in 5 seconds showing high spark rate and nearly zero current & voltage.	<ol style="list-style-type: none"> <li>Secondary current <b>Max Limit</b> set much lower than T-R nameplate.</li> <li>60 Hz. noise on KV feedback signal.</li> </ol>	<ol style="list-style-type: none"> <li>Referring to <i>section 8.3</i> set the Max Secondary Current Limit up to T-R secondary current nameplate rating.</li> <li>If installing jumpers JP71 and JP 81 in active position corrects problem, correct apparent wiring problem or source of interference.</li> </ol>
15.2.15	Control operates at 160° Conduction Angle but does not reach Primary or Secondary Current Limit.	<ol style="list-style-type: none"> <li>Too much inductance in the primary circuit of the T-R set.</li> </ol>	<ol style="list-style-type: none"> <li>Reduce inductance by changing the taps on the Current Limiting Reactor (CLR) and/or the T-R set.</li> </ol>
15.2.16	<b>Unbalance</b> trip or erratic firing of one or both SCR's.	<ol style="list-style-type: none"> <li>Gate to cathode wiring reversed or open to one or both SCR's.</li> <li>One SCR not firing.</li> <li>Faulty T-R diodes.</li> <li>One SCR is shorted.</li> </ol>	<ol style="list-style-type: none"> <li>Check and correct SCR gate wiring from <b>INTERFACE PCB J7 terminals 3 - 4 and 5 - 7</b> to the SCR's. If the polarity is reversed the SCR's may not fire at all or may fire erratically.</li> <li>2a. Blown SCR fuse.</li> <li>2b. Perform checks listed in <i>Table 22, item 15.2.11</i>.</li> <li>3. Replace T-R high voltage diode stack.</li> <li>4. Disconnect both pairs of SCR gate leads from <b>INTERFACE PCB J7 terminals 3 - 4 and 5 - 6</b> and short the gate to cathode lead for each SCR. Restart the control. If current flows or the control trips on <b>Unbalance</b>, one of the SCR's is faulty. Replace SCR.</li> </ol>

**Table 22 (con't) - MVC-IV Operational Problem Trouble Shooting Guide**



# MVC IV VOLTAGE CONTROL MANUAL

NEUNDORFER PRECIPITATOR KNOWLEDGE



## 15.3 MVC-IV Setup Problems

Occasionally, the MVC-IV may refuse to allow the operator to make the desired adjustments to operating setpoints. This is usually caused by errors in T-R CT setup, Max Secondary Current Limit, or KV divider size adjustments. *Table 23* lists typically encountered MVC-IV setup problems and their solutions.

Find the entry in *Table 23* that most closely describes the observed problem and follow the cause and solution suggestions.

Certain problems result in an error code being displayed in the **Auxiliary Functions** digital readout with all decimal points lighted. See *section 15.1* to resolve any error codes before pursuing symptoms in this section.

ITEM	PROBLEM	CAUSE	SOLUTION
15.3.1	Operating setpoints cannot be adjusted up or down.	<ol style="list-style-type: none"> <li>Keypad access is not enabled. <b>Access</b> LED is off.</li> <li>Item to be changed has not been selected (no fast blinking status indicator).</li> <li>Defective keypad.</li> </ol>	<ol style="list-style-type: none"> <li>Refer to <b>DISPLAY</b> manual for entering <b>Access</b> code.</li> <li>Use <b>Next</b> or <b>Last</b> key then <b>Set</b> key to select item to be adjusted.</li> <li>Replace <b>DISPLAY</b> PCB.</li> </ol>
15.3.2	Primary Current Limit cannot be adjusted high enough or low enough.	<ol style="list-style-type: none"> <li>Primary T-R CT setting is incorrect.</li> </ol>	<ol style="list-style-type: none"> <li>See <i>sections 8.0 and 8.2</i> for correct setting and procedure.</li> </ol>
15.3.3	Secondary Current Limit cannot be adjusted high enough.	<ol style="list-style-type: none"> <li>Secondary Max Current Limit setting is incorrect.</li> </ol>	<ol style="list-style-type: none"> <li>See <i>sections 8.0 and 8.3</i> for correct setting and procedure.</li> </ol>
15.3.4	Spark Rate cannot be set above 60 SPM.	<ol style="list-style-type: none"> <li>IE is enabled, that is the IE ratio is not 0.00.</li> </ol>	<ol style="list-style-type: none"> <li>Set IE ratio to 0.00 to access higher Spark Rates. See <i>sections 9.9 &amp; 9.13</i>.</li> </ol>
15.3.5	IE cannot be actuated.	<ol style="list-style-type: none"> <li>SPM set above 60</li> <li>Back Corona software enabled.</li> </ol>	<ol style="list-style-type: none"> <li>Set SPM to 60 or less.</li> <li>Disable Back Corona software. See <i>section 9.12</i>.</li> </ol>
15.3.6	Back Corona software cannot be actuated.	<ol style="list-style-type: none"> <li>IE is enabled.</li> </ol>	<ol style="list-style-type: none"> <li>Disable IE. See <i>section 9.13</i>.</li> </ol>

**Table 23 - MVC-IV Setup Problem Trouble Shooting Guide**





# MVC IV VOLTAGE CONTROL MANUAL

NEUNDORFER PRECIPITATOR KNOWLEDGE



## 15.4 Identifying Operational Problems

On the following pages are examples of typical MVC-IV panel readings that may occur after a control trip. The status indicators and readout values provide useful clues to the cause of the trip. Find the example that matches the observed operating or trip conditions.

The numbers are typical based on a 125 Amp, 45 KV T-R set. KW is assumed to be the default **Auxiliary Functions** display value.

**Problem:** Voltage **Under Limit**. Current near or at limit. Trips off in 30 seconds with near zero KV.

**Cause:** Hard ground on emitting electrode

**Solution:** Isolate shorted T-R bushing. *See section 15.5.4.*

**NEUNDORFER PRECIPITATOR KNOWLEDGE Adaptive Control Technology**

<b>Primary</b> 125 Amps 58 Volts Limit Unbal Limit Low	<b>Secondary</b> 0.76 Amps 0.4 Kilovolts Limit Rap Lim Limit Low	<b>Status</b> <input type="radio"/> T-R On <input checked="" type="radio"/> T-R Off <input type="radio"/> Opt. Limit <input type="radio"/> Int. Trip <input type="radio"/> Ext. Trip <input type="radio"/> Permissive <input type="radio"/> Rem. Start <input type="radio"/> Rem. Stop
<b>Resp</b> 0 Spark Setback Mode Back Cor. IE AutoMax		
<b>Aux Func</b> 2.1 KW Cond Ang Temp °F Data Link Access		

**MVC-IV Multi-processor Voltage Control**

**Problem:** Voltage **Under Limit**. Current near or at limit. Trips off in 30 seconds with low KV.

**Cause:** Shorted diode stack in T-R set. Swinging discharge wire in precipitator.

**Solution:** Remove from service until problem can be resolved during an outage.

**NEUNDORFER PRECIPITATOR KNOWLEDGE Adaptive Control Technology**

<b>Primary</b> 125 Amps 58 Volts Limit Unbal Limit Low	<b>Secondary</b> 0.71 Amps 6.8 Kilovolts Limit Rap Lim Limit Low	<b>Status</b> <input type="radio"/> T-R On <input checked="" type="radio"/> T-R Off <input type="radio"/> Opt. Limit <input type="radio"/> Int. Trip <input type="radio"/> Ext. Trip <input type="radio"/> Permissive <input type="radio"/> Rem. Start <input type="radio"/> Rem. Stop
<b>Resp</b> 0 Spark Setback Mode Back Cor. IE AutoMax		
<b>Aux Func</b> 2.1 KW Cond Ang Temp °F Data Link Access		

**MVC-IV Multi-processor Voltage Control**



# MVC IV VOLTAGE CONTROL MANUAL

NEUNDORFER PRECIPITATOR KNOWLEDGE



**Problem:** All displays read zero or less than 2% of full scale. Control trips off on under voltage.

**Cause:** Open feed to T-R set.  
Faulty CLR.  
Faulty T-R set.

**Solution:** Check all fuses, breakers and connections.  
Check CLR for open circuit.  
Check T-R set for open primary.

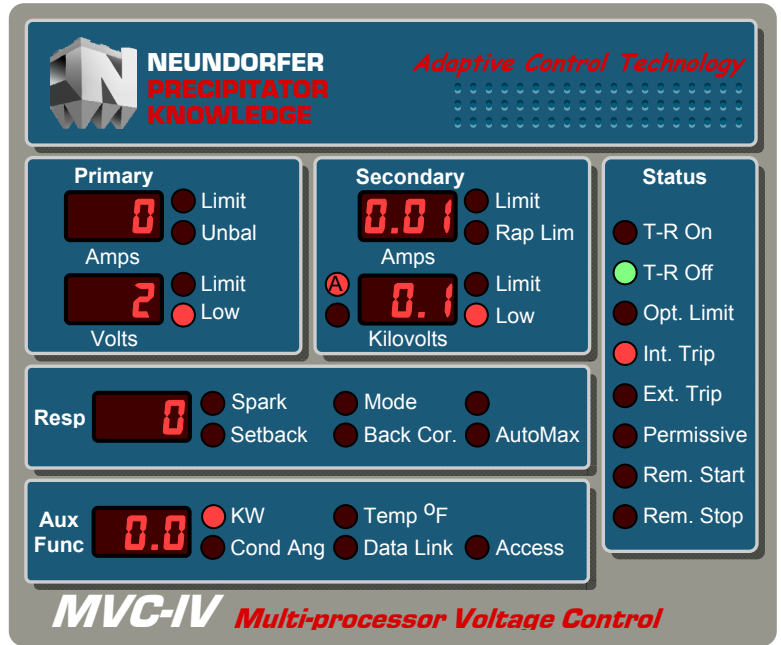

**Problem:** All displays and indicators are dark.

**Cause:** No cabinet power. Main breaker open.  
Blown F1 on **INTERFACE PCB**  
Control transformer fuses blown.  
Faulty control transformer.  
Key interlock switch open.

**Solution:** Locate and correct open circuit.

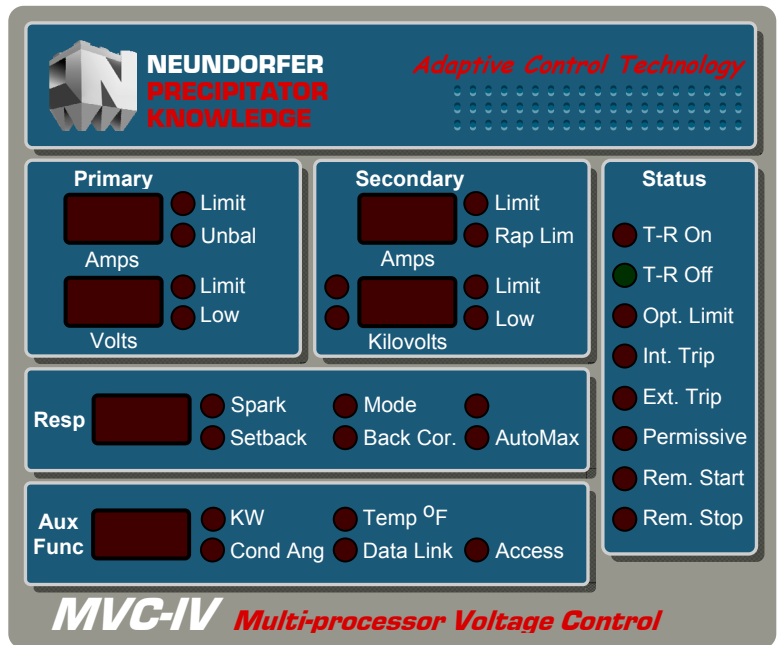



# MVC IV VOLTAGE CONTROL MANUAL

NEUNDORFER PRECIPITATOR KNOWLEDGE



- Problem:** Control will not start.  
Displays limits. Remote Stop illuminated.
- Cause:** Control was stopped by data link command or other remote stop input.
- Solution:** Issue data link start command.  
De-assert Remote Stop input.

**NEUNDORFER PRECIPITATOR KNOWLEDGE** Adaptive Control Technology

<b>Primary</b> 125 Amps 100 Volts Limit Unbal Limit Low	<b>Secondary</b> 0.85 Amps 45.0 Kilovolts Limit Rap Lim Limit Low	<b>Status</b> <input type="radio"/> T-R On <input checked="" type="radio"/> T-R Off <input type="radio"/> Opt. Limit <input type="radio"/> Int. Trip <input type="radio"/> Ext. Trip <input type="radio"/> Permissive <input type="radio"/> Rem. Start <input checked="" type="radio"/> Rem. Stop
<b>Resp</b> 20 Spark Setback Mode Back Cor. AutoMax		
<b>Aux Func</b> 0.0 KW Cond Ang Temp °F Data Link Access		

**MVC-IV Multi-processor Voltage Control**

- Problem:** Control will not start.  
Displays limits. Permissive LED flashing.
- Cause:** No feedback signal from contactor auxiliary contacts.  
Faulty CMR.  
Contactor coil circuit open.  
Faulty K1 relay on INTERFACE PCB.  
Faulty contactor.
- Solution:** If contactor is closing, check signal from auxiliary contacts to INTERFACE PCB.  
Replace CMR.  
Repair contactor coil circuit.  
Replace INTERFACE PCB  
Replace contactor

**NEUNDORFER PRECIPITATOR KNOWLEDGE** Adaptive Control Technology

<b>Primary</b> 125 Amps 100 Volts Limit Unbal Limit Low	<b>Secondary</b> 0.85 Amps 45.0 Kilovolts Limit Rap Lim Limit Low	<b>Status</b> <input type="radio"/> T-R On <input checked="" type="radio"/> T-R Off <input type="radio"/> Opt. Limit <input type="radio"/> Int. Trip <input type="radio"/> Ext. Trip <input checked="" type="radio"/> Permissive <input type="radio"/> Rem. Start <input type="radio"/> Rem. Stop
<b>Resp</b> 20 Spark Setback Mode Back Cor. AutoMax		
<b>Aux Func</b> 0.0 KW Cond Ang Temp °F Data Link Access		

**MVC-IV Multi-processor Voltage Control**



# MVC IV VOLTAGE CONTROL MANUAL

NEUNDORFER PRECIPITATOR KNOWLEDGE



**Problem:** Power level half of normal on dual bushing T-R set. May be spark, current or KV limited.

**Cause:** T-R set output selector switch set incorrectly.  
Open circuit from one of the bushings to the bus section.

**Solution:** Check T-R set output selector switch.  
Check continuity from both bushings to bus section.

**NEUNDORFER PRECIPITATOR KNOWLEDGE** Adaptive Control Technology

<b>Primary</b> 58 Amps 367 Volts Limit, Unbal, Limit, Low	<b>Secondary</b> 0.35 Amps 43.9 Kilovolts Limit, Rap Lim, Limit, Low	<b>Status</b> <input checked="" type="radio"/> T-R On <input type="radio"/> T-R Off <input type="radio"/> Opt. Limit <input type="radio"/> Int. Trip <input type="radio"/> Ext. Trip <input type="radio"/> Permissive <input type="radio"/> Rem. Start <input type="radio"/> Rem. Stop
<b>Resp</b> 21 Spark, Setback, Mode, Back Cor., AutoMax		
<b>Aux Func</b> 14.9 KW, Cond Ang, Temp °F, Data Link, Access		

**MVC-IV Multi-processor Voltage Control**

**Problem:** Spark rate much higher than setpoint.  
Low current  
May trip on **Primary or KV Volts Under Limit** or may keep running.  
Takes longer than 30 seconds to trip off.

**Cause:** Swinging discharge wire in precipitator.

**Solution:** Isolate bushing. Remove wire at next outage. See section 15.5.4.

**NEUNDORFER PRECIPITATOR KNOWLEDGE** Adaptive Control Technology

<b>Primary</b> 7 Amps 132 Volts Limit, Unbal, Limit, Low	<b>Secondary</b> 0.02 Amps 12.4 Kilovolts Limit, Rap Lim, Limit, Low	<b>Status</b> <input type="radio"/> T-R On <input checked="" type="radio"/> T-R Off <input type="radio"/> Opt. Limit <input checked="" type="radio"/> Int. Trip <input type="radio"/> Ext. Trip <input type="radio"/> Permissive <input type="radio"/> Rem. Start <input type="radio"/> Rem. Stop
<b>Resp</b> 147 Spark, Setback, Mode, Back Cor., AutoMax		
<b>Aux Func</b> 0.6 KW, Cond Ang, Temp °F, Data Link, Access		

**MVC-IV Multi-processor Voltage Control**



# MVC IV VOLTAGE CONTROL MANUAL

NEUNDORFER PRECIPITATOR KNOWLEDGE



Problem: Control trips on **Unbalance**.

- Cause:
- Faulty SCR.
  - Blown SCR fuse.
  - Faulty **INTERFACE PCB**.
  - Faulty MVC-IV **LOGIC PCB**.
  - Faulty diode stack in T-R set.
  - T-R set running half wave with large difference in load between bushings.
  - T-R set running half wave with only one bushing connected.

**NEUNDORFER PRECIPITATOR KNOWLEDGE** Adaptive Control Technology

<b>Primary</b> 21 Amps 116 Volts Limit Unbal Limit Low	<b>Secondary</b> 0.12 A 17.4 Kilovolts Limit Rap Lim Limit Low	<b>Status</b> <input type="radio"/> T-R On <input checked="" type="radio"/> T-R Off <input type="radio"/> Opt. Limit <input type="radio"/> Int. Trip <input type="radio"/> Ext. Trip <input type="radio"/> Permissive <input type="radio"/> Rem. Start <input type="radio"/> Rem. Stop
<b>Resp</b> 0 Spark Setback Mode Back Cor. AutoMax		
<b>Aux Func</b> 1.9 KW Cond Ang Temp °F Data Link Access		

**MVC-IV Multi-processor Voltage Control**

Problem: No secondary current display.  
 Control does not sense sparks.  
 May trip on under voltage.  
 Running at primary current limit.

- Cause:
- Shorted secondary current surge arrestor.
  - Shorted secondary current feedback wiring.
  - Faulty **INTERFACE** board
  - Faulty **LOGIC** board

**NEUNDORFER PRECIPITATOR KNOWLEDGE** Adaptive Control Technology

<b>Primary</b> 125 Amps 116 Volts Limit Unbal Limit Low	<b>Secondary</b> 0.00 A 3.4 Kilovolts Limit Rap Lim Limit Low	<b>Status</b> <input checked="" type="radio"/> T-R On <input type="radio"/> T-R Off <input type="radio"/> Opt. Limit <input type="radio"/> Int. Trip <input type="radio"/> Ext. Trip <input type="radio"/> Permissive <input type="radio"/> Rem. Start <input type="radio"/> Rem. Stop
<b>Resp</b> 0 Spark Setback Mode Back Cor. AutoMax		
<b>Aux Func</b> 11.2 KW Cond Ang Temp °F Data Link Access		

**MVC-IV Multi-processor Voltage Control**



# MVC IV VOLTAGE CONTROL MANUAL

NEUNDORFER PRECIPITATOR KNOWLEDGE



**Problem:** No KV display, control trips on under voltage.

**Cause:** Shorted KV surge protector.  
Shorted or open KV feedback wiring.  
Faulty KV divider.  
Faulty INTERFACE board  
Faulty LOGIC board

**Solution:** Temporarily disable the defective KV A or B input by setting the under limit to 0.0 to prevent trips.  
*See sections 9.7 and 9.8.*

**NEUNDORFER PRECIPITATOR KNOWLEDGE** Adaptive Control Technology

**Primary**  
 112 Amps (Limit, Unbal)  
 389 Volts (Limit, Low)

**Secondary**  
 0.78 Amps (Limit, Rap Lim)  
 0.0 Kilovolts (Limit, Low)

**Resp** 30 (Spark, Setback, Mode, Back Cor., AutoMax)

**Aux Func** 34.8 (KW, Temp °F, Cond Ang, Data Link, Access)

**Status**  
 ● T-R On  
 ● T-R Off  
 ● Opt. Limit  
 ● Int. Trip  
 ● Ext. Trip  
 ● Permissive  
 ● Rem. Start  
 ● Rem. Stop

**MVC-IV Multi-processor Voltage Control**

**Problem:** Primary and or secondary **Over Limit** trip in less than 2 seconds.

**Cause:** Shorted SCR.  
One SCR installed backwards.  
SCR stack wired incorrectly.  
Defective INTERFACE PCB.

**NEUNDORFER PRECIPITATOR KNOWLEDGE** Adaptive Control Technology

**Primary**  
 23 Amps (Limit, Unbal)  
 76 Volts (Limit, Low)

**Secondary**  
 0.12 Amps (Limit, Rap Lim)  
 1.2 Kilovolts (Limit, Low)

**Resp** 0 (Spark, Setback, Mode, Back Cor., AutoMax)

**Aux Func** 1.4 (KW, Temp °F, Cond Ang, Data Link, Access)

**Status**  
 ● T-R On  
 ● T-R Off  
 ● Opt. Limit  
 ● Int. Trip  
 ● Ext. Trip  
 ● Permissive  
 ● Rem. Start  
 ● Rem. Stop

**MVC-IV Multi-processor Voltage Control**





# MVC IV VOLTAGE CONTROL MANUAL

NEUNDORFER PRECIPITATOR KNOWLEDGE



**Problem:** Control trips instantaneously when started.

**Cause:** Incorrect Opto Coupler Input configuration code.

**Solution:** See section 8.5 to reprogram.

**NEUNDORFER PRECIPITATOR KNOWLEDGE** Adaptive Control Technology

<b>Primary</b> 0 Limit Amps Unbal 3 Limit Volts Low	<b>Secondary</b> 0.00 Limit Amps Rap Lim 0.2 Limit Kilovolts Low	<b>Status</b> <input type="radio"/> T-R On <input checked="" type="radio"/> T-R Off <input type="radio"/> Opt. Limit <input checked="" type="radio"/> Int. Trip <input checked="" type="radio"/> Ext. Trip <input type="radio"/> Permissive <input type="radio"/> Rem. Start <input type="radio"/> Rem. Stop
<b>Resp</b> 0 Spark Mode Setback Back Cor. AutoMax		
<b>Aux Func</b> 0.0 KW Temp °F Cond Ang Data Link Access		

**MVC-IV Multi-processor Voltage Control**

**Problem:** Control trips after about 5 seconds showing near zero readings except for high spark rate. Spark and Setback LED's probably on. Conduction Angle at 20.

**Cause:** Incorrect KV Divider setting. Noise on KV signal. Missing KV filter with unbalanced KV feedback wiring.

**Solution:** See section 8.4 to set divider value. Refer to sections 5.7 for discussion of KV feedback wiring and filters.

**NEUNDORFER PRECIPITATOR KNOWLEDGE** Adaptive Control Technology

<b>Primary</b> 0 Limit Amps Unbal 3 Limit Volts Low	<b>Secondary</b> 0.00 Limit Amps Rap Lim 0.2 Limit Kilovolts Low	<b>Status</b> <input type="radio"/> T-R On <input checked="" type="radio"/> T-R Off <input type="radio"/> Opt. Limit <input checked="" type="radio"/> Int. Trip <input checked="" type="radio"/> Ext. Trip <input type="radio"/> Permissive <input type="radio"/> Rem. Start <input type="radio"/> Rem. Stop
<b>Resp</b> 87 Spark Mode Setback Back Cor. AutoMax		
<b>Aux Func</b> 0.0 KW Temp °F Cond Ang Data Link Access		

**MVC-IV Multi-processor Voltage Control**



# MVC IV VOLTAGE CONTROL MANUAL

NEUNDORFER PRECIPITATOR KNOWLEDGE



## 15.5 Precipitator Trouble Shooting Guide

Precipitator operational problems often arise that are external to the MVC-IV controller. The MVC-IV is merely the messenger since it is usually the only window into precipitator operations.

It is important to be able to determine which symptoms are indicative of a control problem and which indicate an external problem. External problems may be with the rapping system, ash

handling system, fuel, flue gas conditioning, or precipitator mechanical condition.

This section does not attempt to be a precipitator training manual, but merely touches on the more common problems. Find the entry in *Table 24* that most closely describes the observed problem and follow the cause and solution suggestions.

ITEM	PROBLEM	CAUSE	SOLUTION
15.5.1	<b>Unbalance</b> trip	1. Operating a dual bushing T-R set in double half wave can cause <b>Unbalance</b> trips if the load differs significantly between bushings.	1. Switch T-R set to full wave on each bushing.
15.5.2	Control trips on Setback, and <b>T-R Secondary KV Over Limit</b> .	1. High resistivity inside the precipitator causes the secondary voltage to increase at very low current.	1. More inductance in the primary circuit of the T-R set, will allow the control to operate at higher Conduction Angle. Inductance can be added by changing the taps on the Current Limiting Reactor (CLR) and/or the T-R set.
15.5.3	Spark rate greatly exceeds SPM setting, <b>Setback</b> light is <i>not</i> flashing.	1. Rapidly changing spark over voltage inside precipitator. 2. Swinging discharge wire inside precipitator.	1a. Increase Setback. <i>See section 9.10.</i> 1b. Increase Spark Rate. <i>See section 9.9.</i> 2. Remove or replace discharge wire.
15.5.4	Spark rate greatly exceeds SPM setting, <b>Setback</b> light is flashing.	1a. Close clearance in precipitator between discharge wires and plates. 1b. Close clearance between high voltage and ground. 1c. Insulator tracking over. 1d. Swinging discharge wire. 2. Problem with KV feedback circuit picking up noise	1. Isolate part of the electrical field that the T-R set feeds. This can be done with dual bushing T-R set switches or high voltage duct switches. Turn the control off before switching. Re-power control feeding each electrical section separately to determine where the internal clearance problem is. Leave this section off and run the control normally until the unit is off line and an internal inspection can be made. 2. Disable KV monitoring. If that resolves the problem, correct wiring issues.

Table 24 - Precipitator Trouble Shooting Guide (con't next page)



# MVC IV VOLTAGE CONTROL MANUAL

NEUNDORFER PRECIPITATOR KNOWLEDGE



ITEM	PROBLEM	CAUSE	SOLUTION
15.5.5	High primary Amps. Low primary Volts. High secondary current. Low or no KV.	Shorted electrical field or low resistive path to ground. Causes: 1a. Broken wire. 1b. Ash build up in the hoppers. 1c. Warped plates touching wires. 1d. Dirty, broken or cracked insulators tracking to ground. 1e. Defective feed through bushings.	1. Isolate part of the electrical field that the T-R set feeds. This can be done with dual bushing T-R set switches or high voltage duct switches. Turn the control off before switching. Re-power control feeding each electrical section separately to determine where the internal clearance problem is. Leave this section off and run the control normally until the unit is off line and an internal inspection can be made to determine the exact cause of the problem.
15.5.6	Low pri Amps. High pri Volts. Low sec current.  High KV.	An increase of resistance in the precipitator. Causes: 1. Plate buildup. 2. Wire buildup. 3. Open conductor between T-R and precipitator.  4. Change in ash chemistry.	1. Diagnose & correct rapping system problem. 2. Diagnose & correct rapping system problem. 3. Shut down T-R set. Ground out T-R and field. When safe inspect and repair high voltage transmission system. 4. If opacity is OK, may be new normal operation. Adjust flue gas conditioning system. Try IE or Back Corona software.
15.5.7	High pri Amps. Pri Volts lower than normal. Low to no sec current. Low KV.	1. Shorted T-R set secondary. 2a. Shorted secondary current sense resistor or surge protector. 2b. Damaged secondary current feedback wiring.	1. Megger T-R set following all safety precautions. 2. Inspect and repair as needed.
15.5.8	High pri Amps. Low pri Volts. Low to no sec current. Low to no KV.	1. Short in T-R primary circuit. 2. Shorted T-R diode stack. 3. Shorted bus section. 4. No secondary current feedback signal.	1. Inspect and repair as needed. 2. Megger diode stack and replace as needed. 3. Locate and repair short. 4. Inspect and repair current sensing resistor, surge arrester and feedback wiring.

**Table 24 (con't) - Precipitator Trouble Shooting Guide**



## 15.6 Data Link Trouble Shooting

The POS and display data links utilize RS-485 electrical standards in a half duplex format using Neundorfer proprietary protocols.

The POS data link is a multi-drop communication bus. That is, all controllers are directly connected to a common twisted pair transmission line. A single inoperative controller can disrupt communications for the entire network. If the installation uses a single display for a group of controls, then the display network is also a multi-drop bus and is subject to the same trouble shooting guidelines as the POS data link.

The RS-485 standard uses a twisted pair cable driven differentially. One line is driven toward the

+5 V supply level while the other is driven toward ground. Looking differentially across the two lines should produce signal levels that swing equally above and below the zero level. The RS-485 specification calls for the positive and negative excursions to match in magnitude within 200 mV. The specification requires a minimum  $\pm 1.5V$  signal swing under worst case bus loading.

Figures 11 through 14 show correct RS-485 signaling levels for various line terminations. The top trace in figure 11 shows the differential signal between Data A (+) and Data B (-) on a link with only AC termination and line biasing provided by the end-of-line MVC-IV control. The bottom trace shows the same differential signal with an

additional 110 Ohm line-to-line DC terminator. Notice that the magnitude of signal swing is reduced from  $\pm 4.5$  Volts to  $\pm 3.0$  Volts, but symmetry about the zero point is maintained. Also, the DC termination reduces the quiescent signal level from approximately +4.2 V to approximately +0.1 V.

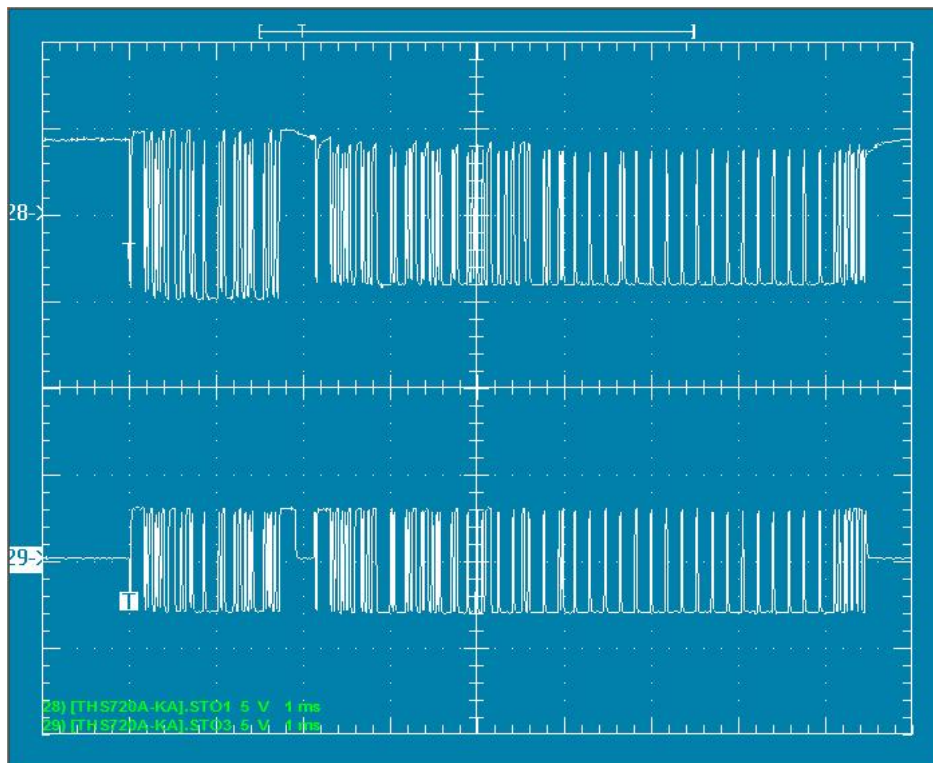

Figure 11 - RS-485 Differential Signal at 5 V/div., 1 msec./div.  
Top - With AC terminator only  
Bottom - With additional 110 Ohms line to line



# MVC IV VOLTAGE CONTROL MANUAL

NEUNDORFER PRECIPITATOR KNOWLEDGE



Figure 12 is the leading part of figure 11 expanded to 10 x sweep speed. The rounding of the waveform edges is a function of the AC terminator, cable length and total network configuration, but notice that the leading edges of the transitions have a steep rise and fall to the  $\pm 1.5V$  specification level and symmetry about the zero point is maintained.

Figure 13 shows the individual Data A (+) and Data B (-) signals with respect to ground on a link with only AC termination and line biasing provided

by the end-of-line MVC-IV control. Each data line swings from near ground to approximately 4.4 Volts. Figure 14 is the same signals with an additional 110 Ohm line-to-line DC terminator. The signal lines now swing from 1.0 Volt to 4.1 Volts. Note that the two data lines both swing nearly equal amounts and always in the opposite direction. The magnitude of high and low level swing and quiescent level will vary with data line loading as demonstrated by the difference between figures 13 and 14.

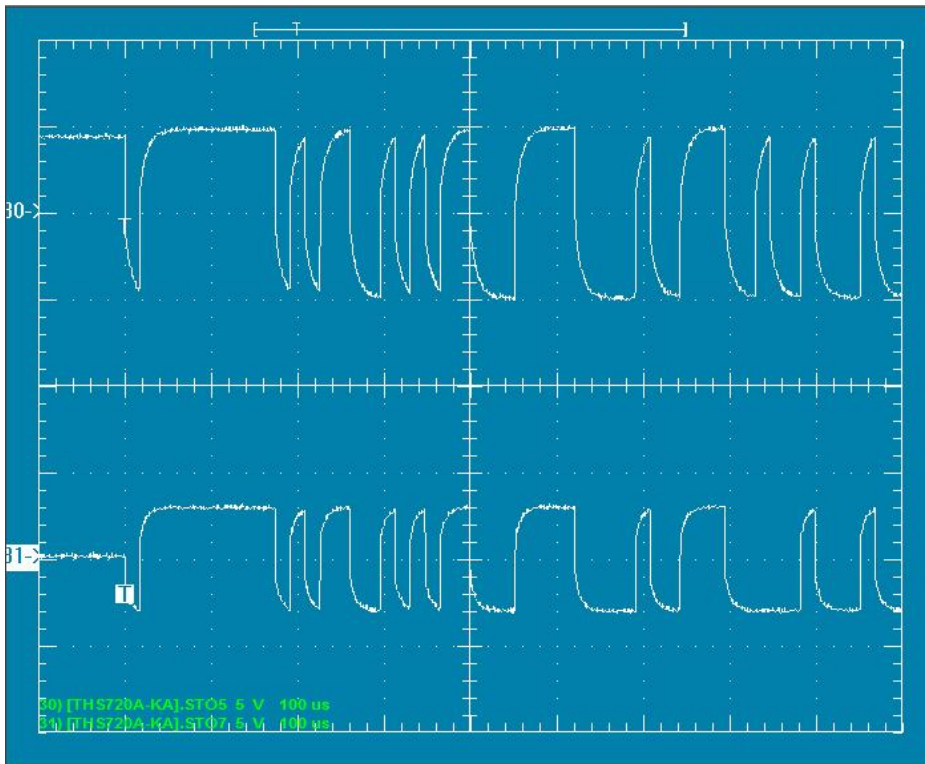

Figure 12 - RS-485 Differential Signal at 5 V/div., 100 usec./div.  
Top - With AC terminator only.  
Bottom - With additional 110 Ohms line to line.





# MVC IV VOLTAGE CONTROL MANUAL

NEUNDORFER PRECIPITATOR KNOWLEDGE



Figure 13

RS-485 Data Line Signals  
Relative to Ground.

2 V/div., 100 usec./div. with  
AC Termination Only.

Top - Data A (+) relative  
to ground

Bottom - Data B (-)  
relative to ground.

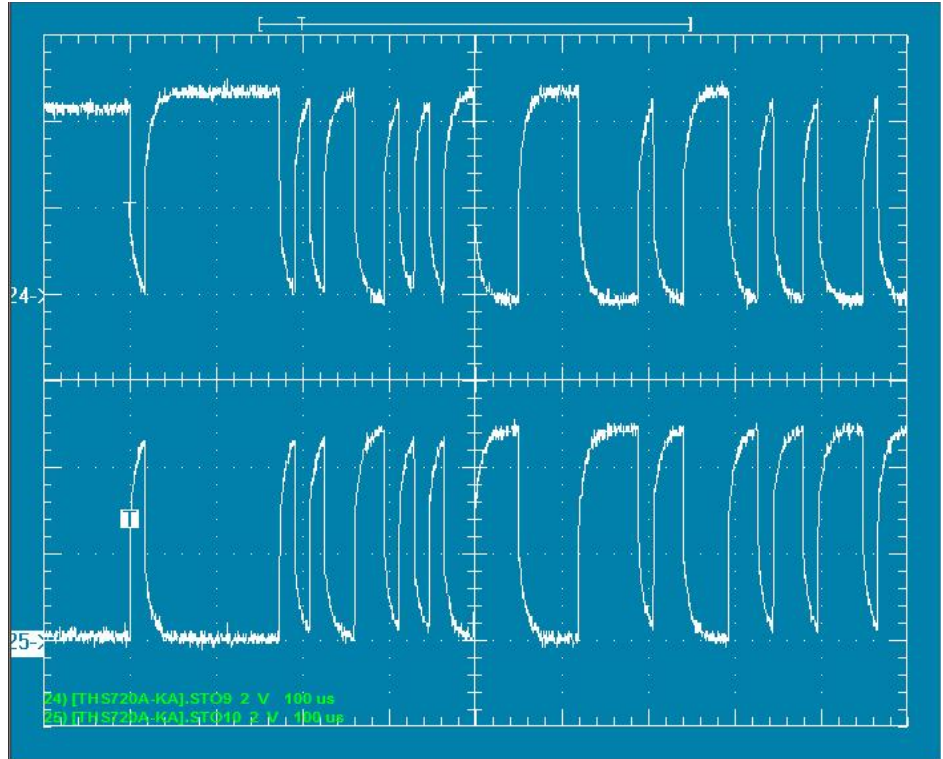

Figure 14

RS-485 Data Line Signals  
Relative to Ground.

2 V/div., 100 usec./div. with  
110 Ohm Line-to-Line DC  
Termination.

Top - Data A (+) relative  
to ground

Bottom - Data B (-)  
relative to ground.

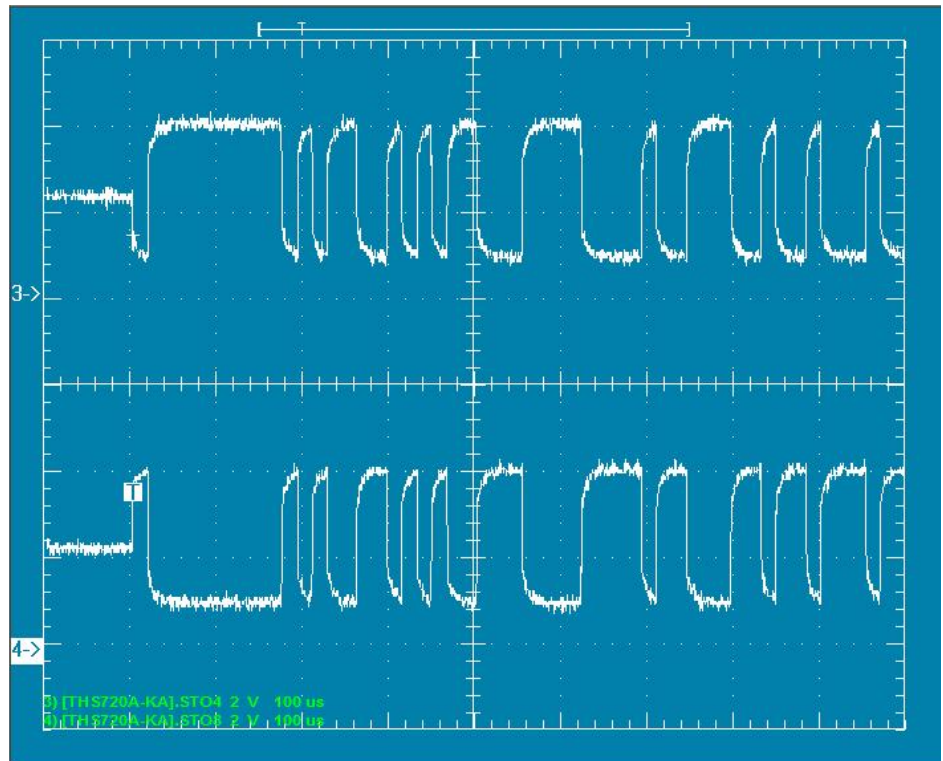





Data link troubleshooting can be divided into two broad categories - new installations that have never functioned properly and installations that once functioned properly and now have failed.

For new installations, start by verifying all wiring. A common problem is swapped Data A (+) and Data B (-) lines. Verify that all converter and repeater units are powered and set for the correct baud rate. A suggestion would be to disconnect all controls from the network, except the one control at the start of the data link closest to the POS computer. Establish communications with that control before adding more controls to the link. If communications cannot be established with that control, there is likely a problem with the isolated link between the POS computer and the start of the RS-485 link at the controls. Use a laptop computer with known operational POS to directly connect to the start-of-line control to verify control operation. It may become necessary to add control to the link one by one while observing the data link electrical signals with an oscilloscope to locate the problem.

For existing once operational data links, there are two basic types of failures. The first is a control that simply stops talking without affecting communications with any other controllers. Replace the affected MVC-IV logic board. The more common communication problems occur if an RS-485 driver fails and loads the transmission line preventing proper signal levels. Finding the offending controller can be challenging.

If some of the controls on a common cable are talking and some are not, the problem most likely is in the last control nearest the POS computer that is still communicating or the first one that is not

communicating. Turning off cabinet power to a suspect control will disconnect it from the data line to test if that is the problem control. Note that firmware V2.1b and later will allow disconnecting the control from the data line by setting the POS Access Enable setting to "OFF" without the need to turn off the T-R set or cabinet power. See [section 9.19](#). Diagnostic routines in future firmware releases will have some ability to self diagnose the RS-485 hardware and automatically disconnect from the data line if a fault is detected.

Sometimes the only way to find the bad controller is to divide the physical data link in half to determine which half has the problem. Then divide the half with the problem and so on until the problem control is identified.

*Figures 15 and 16* are examples of a controller on the data link with a failed driver chip that is loading the Data B (-) transmission line.

*Figure 15* is the differential signal between the Data A (+) and Data B (-) lines taken under the same conditions as the bottom trace of *figure 12*. Instead of swinging  $\pm 3.0$  Volts as in *figure 12*, it is swinging + 3.6 Volts and only - 0.5 Volts.

*Figure 16* shows the individual Data A (+) and Data B (-) lines relative to ground. Data A (+) is swinging from 0.3 Volts to 3.9 Volts as expected, but Data B (-) line is swinging from 0.3 Volt to 1.0 Volt. Compare this to *figure 14*.

The message will likely not be understood by the target controller, and the failed driver chip will probably block all communications.



# MVC IV VOLTAGE CONTROL MANUAL

NEUNDORFER PRECIPITATOR KNOWLEDGE



Figure 15

RS-485 Differential Signal with a failed "B" line driver.

2 V/div., 100 us/div. with 110 Ohm Line-to-Line Termination.

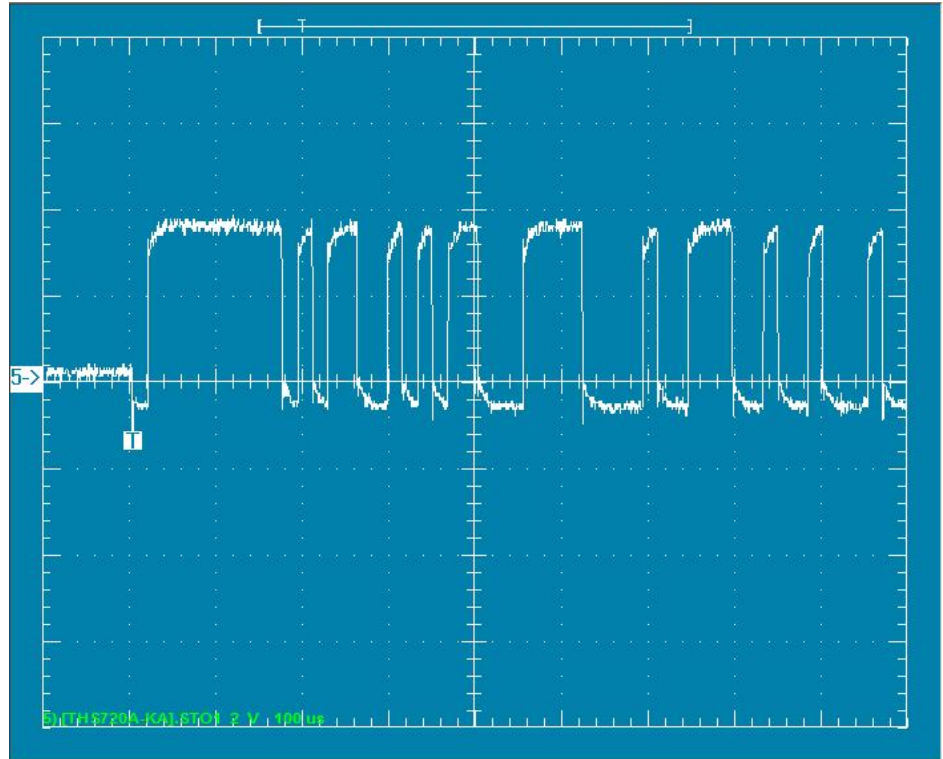

Figure 16

RS-485 Data Line Signals Relative to Ground with a failed "B" line driver.

2 V/div., 100 us/div. with 110 Ohm Line-to-Line Termination

Top - Data A (+) relative to ground.

Bottom - Data B (-) relative to ground.

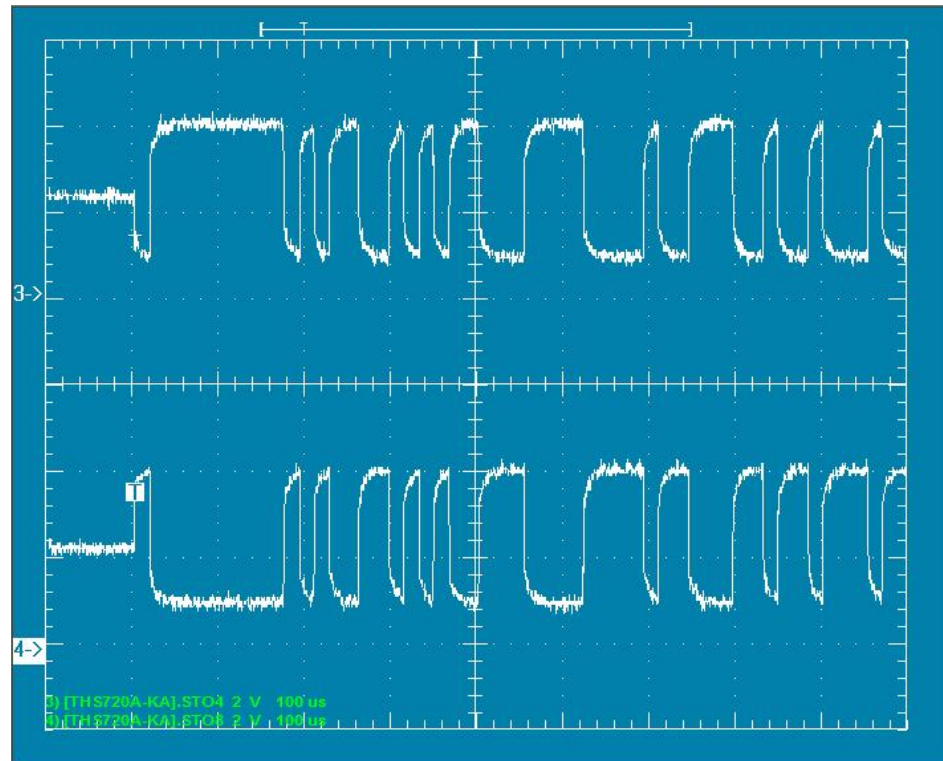



# MVC IV VOLTAGE CONTROL MANUAL

NEUNDORFER PRECIPITATOR KNOWLEDGE



This page intentionally blank.



# MVC IV VOLTAGE CONTROL MANUAL

NEUNDORFER PRECIPITATOR KNOWLEDGE



## APPENDIX

### A. CURRENT MONITOR RELAY SETUP INSTRUCTIONS & DATA SHEET

The optional Current Monitor Relay (CMR) monitors T-R primary current **completely independent** of the MVC-IV LOGIC system. If a fault should occur in the MVC-IV causing a runaway condition, the Current Monitor Relay will detect the over current and turn off the T-R power by directly interrupting the main contactor coil power circuit.

The CMR device is a Crouzet model EIH, part number 84 871 033. It is connected to sense 0 - 5 amps full scale input from a dedicated XXX : 5 current transformer.

There is a two pole configuration DIP switch, two timer settings, a hysteresis setting and a current trip level setting. The DIP switch is set for "Over current" with "Memory." Set timer T1 for one second and timer T2 for two seconds. Set Hysteresis to 15%. Set the over current threshold to trip at 1.25 times T-R set primary current rating.

For example, assume a 150 Amp T-R set.  
Recommended Current Transformer = 250:5  
Recommended Trip point = 1.25 x 150A = 187.5A  
I-Value setting = (187.5A /250A) = 75%.  
Set the I-Value dial to 75%.

The following table summarizes the connections and settings for the Crouzet EIH 84 871 033 CMR.

Item	Setting
CT Connection	Terminal E2 to M
DIP switch 1	Overload
DIP switch 1	With Memory
T1 Timer	1 sec.
T2 Timer	2 sec.
Hysteresis	15%
I Value	As required to set trip at 1.25 times T-R rating

The complete Crouzet data sheet is on the following pages.



# MVC IV VOLTAGE CONTROL MANUAL

NEUNDORFER PRECIPITATOR KNOWLEDGE



EIH 84 871 033 CMR Data Sheet, page 1 of 3

## Current control

### → EI AC/DC current control

- Space savings, accurate measurement and optimized functions all improve the efficiency of your electrical installation.
- Control : Select "Over-current" or "Under-current" control mode, by means of a dip switch on the underside of the unit.
- Safety : Choose whether or not to activate the fault memorisation function, and set the threshold crossing delay T1 and the inhibit time delay T2 in the same way. In addition, AC/DC mode is detected automatically.
- Accuracy : 3 products, EIL, EIH or EIT enable you to choose the best product for greater accuracy of measurement, provided by a microcontroller.



## Specifications

	EIL	EIH	EIT
<b>Supply voltage</b>			
24 V DC	84 871 020	84 871 030	84 871 040
24 V AC	84 871 021	84 871 031	84 871 041
48 V AC	84 871 022	84 871 032	84 871 042
120 V AC	84 871 023	84 871 033	84 871 043
230 V AC	84 871 024	84 871 034	84 871 044
<b>Measurement range</b>	2 → 500 mA	0.1 → 10 A	10 → 100 A with current transformer
<b>Inputs</b>	E1-M E2-M E3-M	E1-M E2-M E3-M	E1-M
<b>Sensitivity</b>	E1-M : 2 → 20 mA E2-M : 10 → 100 mA E3-M : 50 → 500 mA	E1-M : 0.1 → 1 A E2-M : 0.5 → 5 A E3-M : 1 → 10 A	10 → 100 A
<b>Input resistance</b>	E1-M : 5 Ω E2-M : 1 Ω E3-M : 0.2 Ω	E1-M : 0.1 Ω E2-M : 0.02 Ω E3-M : 0.01 Ω	20 Ω

For more information [www.crouzet.com](http://www.crouzet.com)





# MVC IV VOLTAGE CONTROL MANUAL

NEUNDORFER PRECIPITATOR KNOWLEDGE



## EIH 84 871 033 CMR Data Sheet, page 2 of 3

### General characteristics

Supply voltage $U_n$	230 V, 110 V, 48 V, 24 V a 50 / 60 Hz (galvanic isolation by transformer) 24 V DC (No galvanic isolation). In this case, the product power supply and measuring circuit power supply must be electrically isolated.
Operating range	0.85 → 1.15 $U_n$
Maximum power consumption	3 VA AC 1 W DC
Frequency of measured signal	40 → 500 Hz
Adjustable hysteresis	5 → 50 % of the displayed threshold
Threshold value	10 → 100 % of the measurement range
Display accuracy of the preset threshold	±10 %
Repetition accuracy with constant parameters	±0.1 %
Drift Voltage	±0.1 % (±10 % $U_n$ )
Drift Temperature	±0.02 %
Delays on power up (T2)	1 s → 20 s ±10 %
Delay on energisation T1	0.1 s → 3 s ±10 %
Delay on pick-up	500 ms
Output relay	1 changeover AgNi, 8A AC max
Temperature limit operation (°C)	-20 → +50
Temperature limits stored (°C)	-40 → +70
Weight (g)	140

### Dimensions

EIL / EIH / EIT

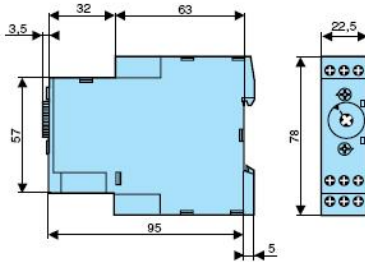

### Connections

EIL / EIH

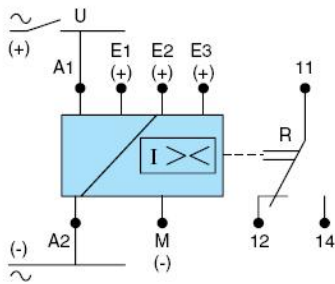

EIT

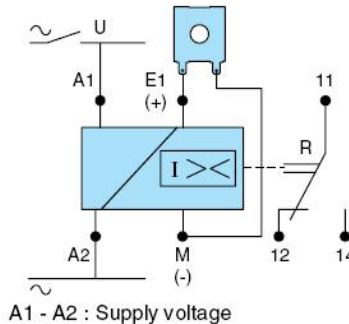

For more information [www.crouzet.com](http://www.crouzet.com)





# MVC IV VOLTAGE CONTROL MANUAL

NEUNDORFER PRECIPITATOR KNOWLEDGE



## EIH 84 871 033 CMR Data Sheet, page 3 of 3

### Principles

#### AC/DC control with memory

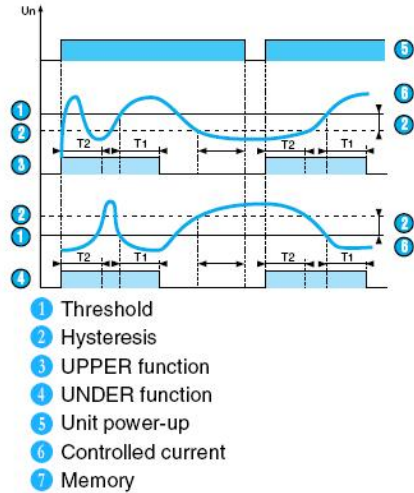

#### Operating principle

##### AC/DC control without memory

When the value of the controlled current, either AC or DC, reaches the threshold displayed on the front face, the output relay changes state at the end of time delay T1. It returns instantly to the initial state when the current drops below the hysteresis threshold, or when the power supply is disconnected.

##### AC/DC control with memory

The output relay changes state at the end of time delay T1 and remains latched in this position. To reset the memory function the auxiliary supply must be disconnected.

##### Over-current function (UPPER)

The time delay on energisation T2 prevents current peaks due to motor starting. The delay on upward crossing of threshold T1 provides immunity to transients and other interference, thereby preventing spurious triggering of the output relay.

##### Under-current function (UNDER)

The time delay on energisation T2 prevents the occurrence of current troughs. The delay on downward crossing of threshold T1 provides immunity to random dips, thereby preventing spurious triggering of the output relay.

**Note :** In underload function, the absolute value of the hysteresis cannot be greater than the measurement range maximum.

#### AC/DC control without memory

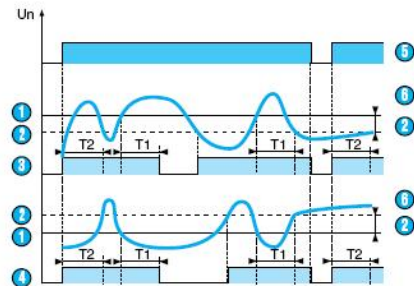

- 1 Threshold
- 2 Hysteresis
- 3 UPPER function
- 4 UNDER function
- 5 Unit power-up
- 6 Controlled current



For more information [www.crouzet.com](http://www.crouzet.com)



## B. FIBER OPTIC MODEM SETUP INSTRUCTIONS & DATA SHEET

Data communications within a local group of controllers uses RS-485 electrical standards on twisted pair cable. To avoid possible ground offset problems, communications beyond a local room requires electrical isolation. Our preferred method is with fiber optic cable, although electrically isolated RS-485 repeaters could also be used.

The standard device we provide is a Black Box model MED100A. It can convert between fiber and RS-232 or RS-485 and can function in a multi-drop mode for fiber links to multiple control rooms.

This section provides setup information for the MED100A as well as a copy of the manufacturer’s data sheet. The MED100A has electrical connections labeled A through H and J through M, fiber connections labeled TX and RX, and an eight pole DIP switch, SW1. Different connections and switch settings are required based on how the module is being used.

The module may be used as:

1. RS232 to fiber converter at the POS computer.
2. RS-485 to fiber converter at an MVC-IV REMOTE DISPLAY.
3. Point to point fiber to RS-485 converter at MVC-IV group.
4. Multi-drop fiber to RS-485 converter at MVC-IV group.

The following table lists SW1 position 1 through 5 settings for various baud rate selections. POS to MVC-IV communications utilizes 57.6K baud. MVC-IV REMOTE DISPLAY to MVC-IV controller communications utilizes 76.8K baud.

Baud Rate	Timeout (msec)	Pos. 1	Pos. 2	Pos. 3	Pos. 4	Pos. 5
4800	2.2	OFF	OFF	OFF	OFF	ON
9600	1.3	OFF	OFF	OFF	ON	OFF
19.2K	0.56	OFF	OFF	ON	OFF	OFF
38.4K	0.27	OFF	ON	OFF	OFF	OFF
57.6K	0.22	ON	OFF	OFF	OFF	OFF
76.8K	0.14	ON	OFF	ON	ON	OFF
115.2K	0.10	ON	ON	ON	OFF	OFF

SW1 positions 6, 7 and 8 configure the MED100A for the type of service. The following table lists the useful combinations.

Usage	Pos. 6	Pos. 7	Pos. 8
RS-485, Point to point, Full Duplex	OFF	ON	OFF
RS-485, Point to point, Half Duplex	OFF	ON	ON
RS-485, Multi-drop (fiber repeater) Full Duplex	ON	ON	OFF
RS-485, Multi-drop (fiber repeater) Half duplex	ON	ON	ON
RS-422	OFF	OFF	OFF
RS-422	OFF	OFF	OFF
RS-422	OFF	OFF	OFF
RS-422	OFF	OFF	OFF

The following table lists the MED100A connections.

Note that Black Box denotes RS-485 “A” and “B” lines opposite to our convention. For proper operation, therefore, the MED100A “A” data line is connected to the Neundorfer “B” line and the MED100A “B” data line is connected to the Neundorfer “A” line.

Either the RS-232 or the RS-485 connections can be used, but not both.

tem	Terminal	Notes
RS-232 RD	D	
RS-232 TXD	A	
RS-232 Common	B	
RS-485 (A)	G & K	Jumper G to K
RS-485 (B)	H & L	Jumper H to L
RS-485 Shields	M	Provides ground
No Connection	E	
+24VDC power	F	+10 to +30 VDC
Power common	C	Connect to Earth ground



# MVC IV VOLTAGE CONTROL MANUAL

NEUNDORFER PRECIPITATOR KNOWLEDGE



## MED100A Fiber Optic Modem Data Sheet, page 1 of 4

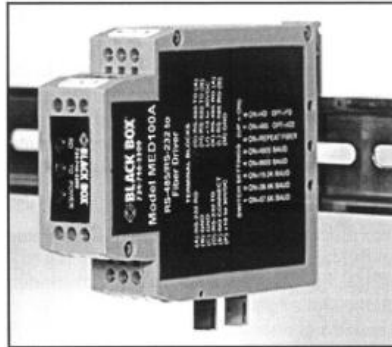

### Model MED100A Fiber Optic Modem Sends RS-232, 422, 485 Signals Up to 2.5 Miles (4 km) CE

#### Description

The MED100A is designed to provide the most versatile connection possible between any asynchronous serial equipment using Fiber Optic cable. It allows any two pieces of asynchronous serial equipment to communicate full or half-duplex over two fibers at typical distances up to 2.5 miles (4 km). The converter can also be set up in "Repeater" mode to create a multi-drop master/slave configuration, allowing one serial device to talk to multiple slave devices around a fiber ring. The DIN rail mountable box makes it ideal for industrial cabinets and enclosures.

RS-232 data signals up to 115.2K bps and RS-422, or RS-485 data signals up to 460K bps are supported. Different standards can be mixed and matched to allow RS-232 devices to connect to your RS-422 or RS-485 system. This means the MED100A can replace converters and isolators when connecting remote devices, while providing the EMI/RFI and transient immunity of optical fiber.

The MED100A supports both the Transmit and Receive data lines, and provides full hardware control of the RS-422/485 driver with automatic Send Data Control circuit. Timeouts are dip-switch selectable between 0.10 and 2.2 ms. All serial connections are provided on terminal blocks, while the multimode fiber is connected via two ST connectors. The unit is powered by 10 to 30VDC at 140 mA max.

#### RS-232 Connections

Connection of the MED100A is simple and straightforward. The RS-232 driver and receiver are connected to 2 terminal blocks. The RS-232 DATA OUT is on terminal block (A), and the RS-232 DATA IN is on terminal block (D). Ground is located on terminal block (B) and (C), and power comes in on terminal block (F).

#### RS-422 and RS-485 Connections

The RS-422/485 driver and receiver are connected to 4 terminal blocks. Signal ground is on terminal block (M), and power comes in on terminal block (J). When connecting to a four-wire RS-422/485 device or system, connect the output of your device to terminal block (L) (RDB or RD+) and terminal block (K) (RDA or RD+). Connect the input to your device to terminal block (H) (TDB or TD+) and terminal block (G) (TDA or TD-). For two-wire RS-485 systems, the driver and receiver of the MED100A must be connected together by tying terminal blocks (L) and (H) together and (G) and (K) together. This allows the MED100A to communicate half-duplex over the same pair. Refer to Figure 1 for connection diagrams to your RS-422 or RS-485 equipment.

If termination is needed, the PCB is laid out to allow a termination resistor (Rt) to be soldered in across the RD(A) and RD(B) lines. The off-state bias resistor values can also be changed by removing R8 and R16 and replacing them with through-hole components.

Figure 1: RS-422/485 Connection Diagrams

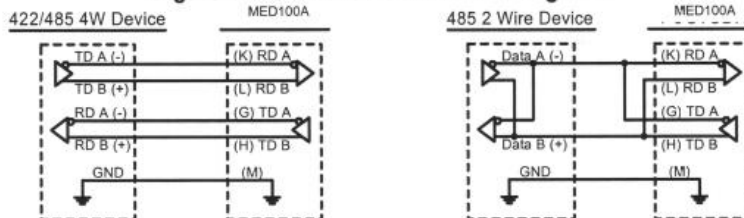

Black Box Corporation - 1000 Park Drive - Lawrence, PA 15055-1018  
Tech Support and Ordering: 724-746-5500 - Fax: 724-746-0746  
To contact us about Black Box products or services: [info@blackbox.com](mailto:info@blackbox.com)





# MVC IV VOLTAGE CONTROL MANUAL

NEUNDORFER PRECIPITATOR KNOWLEDGE



## MED100A Fiber Optic Modem Data Sheet, page 2 of 4

### Fiber Optic Connections

The MED100A uses a separate LED emitter and photo-detector operating at 820 nm wavelength. Connections to the emitter and detector are on ST type connectors. Most multimode glass fiber size can be used including 50/125 μm, 62.5/125 μm, 100/140 μm, and 200 μm. One fiber is required for each connection between a transmitter and receiver. In a point to point configuration, two fibers are required between the two modems, one for data in each direction. A multi-drop ring configuration requires one fiber between TX and RX around the loop. See Figure 2 for typical point-to-point and multi-drop configurations.

The most important consideration in planning the fiber optic link is the "power budget" of the fiber modem. This value represents the amount of loss in dB that can be present in the link between the two modems before the units fail to perform properly. This value includes line attenuation as well as connector loss. For the MED100A the typical connector to connector power budget is 12.1 dB. Because 62.5/125 μm cable typically has a line attenuation of 3 dB per Km at 820 nm, the 12.1 dB power budget translates into 2.5 miles (4 km). This assumes no extra connectors or splices in the link. Each extra connection would typically add 0.5 dB of loss, reducing the possible distance by 166 m (547 ft.). The actual loss should be measured before assuming distances.

Figure 2: Typical Setups

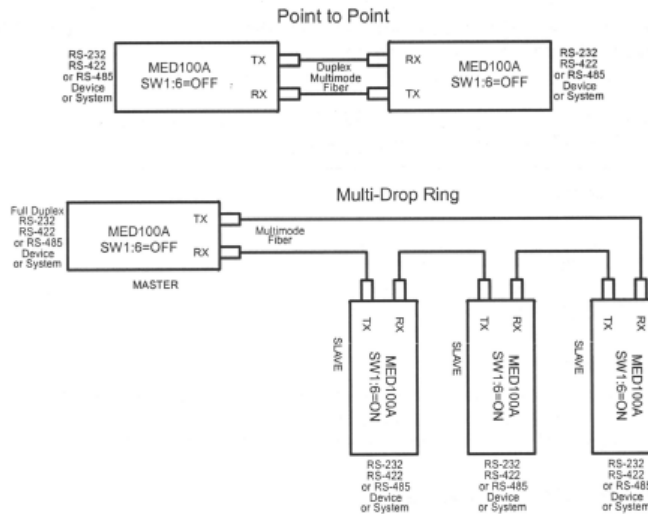

### Dip-Switch Setup

The Dip-Switch (SW1) on the MED100A defines the mode of operation when being used for RS-422 or RS-485. Positions 1 through 5 on the switch determine the timeout of the RS-485 driver. Because the driver is controlled by hardware, a specific time must be set to tell the hardware how long to wait for data on the fiber side before turning off the RS-422/485 driver. If this time is set too short, the driver could be disabled before transmission is complete, resulting in data corruption. If the time is set too long, the RS-485 device may respond before the RS-422/485 driver in the MED100A is disabled, corrupting this response. We recommend that the timeout be set for approximately one character time or longer. The character times for several different baud rates are selectable on switch positions 1 through 5. If you need a different timeout than what is provided, R10 can be removed and replaced with a different value R9. Table 1 shows different timeout values for the switch positions as well as typical R9 replacement values.

Table 1: RS-485 Timeout Selection

Baud Rate	Pos. 1	Pos. 2	Pos. 3	Pos. 4	Pos. 5	R9	Time(ms)
1200	ON	OFF	OFF	OFF	OFF	820 KΩ	8.20
2400	ON	OFF	OFF	OFF	OFF	430 KΩ	4.30
4800	OFF	OFF	OFF	OFF	ON	Not Used	2.20
9600	OFF	OFF	OFF	ON	OFF	Not Used	1.30
19.2K	OFF	OFF	ON	OFF	OFF	Not Used	0.56
38.4K	OFF	ON	OFF	OFF	OFF	Not Used	0.27
57.6K	ON	OFF	OFF	OFF	OFF	Not Used	0.22
76.8K	ON	OFF	ON	ON	OFF	Not Used	0.14
115.2K	ON	ON	ON	OFF	OFF	Not Used	0.10
153.6K	ON	OFF	OFF	OFF	OFF	6.2 KΩ	0.06
230.4K	ON	OFF	OFF	OFF	OFF	4.3 KΩ	0.04
460.8K	ON	OFF	OFF	OFF	OFF	2.2 KΩ	0.02

Black Box Corporation - 1000 Park Drive - Lawrence, PA 15055-1018  
Tech Support and Ordering: 724-746-5500 - Fax: 724-746-0746  
To contact us about Black Box products or services: [info@blackbox.com](mailto:info@blackbox.com)



# MVC IV VOLTAGE CONTROL MANUAL

NEUNDORFER PRECIPITATOR KNOWLEDGE



## MED100A Fiber Optic Modem Data Sheet, page 3 of 4

Position 6 of SW1 sets the unit in a "Multidrop" mode or a "Point-to-Point" mode. When the MED100A is set in a "Multidrop" mode, data arriving on the Fiber Optic receiver is repeated back out the transmitter. When set in a "Point-to-Point" mode, data arriving at the Fiber optic receiver is not sent back out the Fiber Optic transmitter. Position 6 must be turned "On" when the MED100A is to be used in a multi-drop ring configuration. It must be turned "Off" when the MED100A is to be used as either end of a point-to-point communication line. See Figure 3 for typical system setups using the MED100A in its different modes.

Positions 7 and 8 of SW1 determine when the RS-422/485 driver and receiver are enabled. Position 7 controls the driver and Position 8 controls the receiver. For RS-422 operation, set both switches to the "Off" position. For multi-drop RS-485 four-wire systems, position 7 should be "On" and position 8 should be "Off." This allows the receiver to be enabled all of the time and eliminates some possible timing problems. For RS-485 two-wire systems, both switches should be in the "On" position. This disables the RS-422/485 receiver whenever the driver is enabled, preventing data from being echoed back to the fiber side of the MED100A.

Table 2 illustrates the switch settings for typical setups.

Table 2: 422/485 Switch Settings

	Position 7 TX Enable	Position 8 RX Enable
<b>RS-485 2-Wire Mode (half duplex)</b>	ON	ON
<b>RS-485 4-Wire Mode (full duplex)</b>	ON	OFF
<b>RS-422 Mode (full duplex)</b>	OFF	OFF

### Multi-drop Operation

A multi-drop configuration is created by forming a ring of MED100As. Each transmitter is tied to the following converter's receiver, starting at a master node and continuing around to each slave and back to the master. By setting SW1:6 to the "On" position on the slaves, all data sent from the master or preceding slaves is echoed back out the fiber transmitter to the rest of the slaves and eventually back to the master node.

Because all data is echoed back, there are special considerations when constructing a multi-drop system. The master will see its own transmitted data. This means that the master device must be full-duplex (RS-232, RS-422, or four-wire RS-485) and that it must be capable of ignoring or otherwise accepting its own echoed transmission. Slaves must also be able to accept data from previous slaves in the loop.

### Specifications/Features

- Transmission Line: Dual multimode optical cable
- Point-to-Point Transmission: Asynchronous, half or full-duplex
- Multi-Drop Transmission: Asynchronous, half duplex fiber ring
- Interfaces: RS-232, RS-422, or RS-485
- Connectors: Terminal blocks for serial connection, ST connectors for fiber
- Dimensions: 4.3 x 2.3 x 0.95 in (11 x 5.9 x 2.5 cm)
- Power Supply Connections: Terminal blocks
- Recommended Power Supply: # PSD100 (12VDC, Input voltage range: 10-30 VDC)
- Temperature Rating: -40 to +80°C (-40 to +176°F)

All specifications given using 62.5/125µm glass multi-mode fiber.

Table 3: Recommended Maximum MED100 in a Fiber Ring Topology

Baud Rate	RS-232 Operation	RS-422/485 Operation
460.8 kbps	N/A	2
230.4 kbps	N/A	4
115.2 kbps	2	8
57.6 kbps	8	16
38.4 kbps	16	24
19.2 kbps and lower	32	32

Model Number:	MED100A	<b>CE</b>
Description:	DIN mount Fiber Optic Converter	
Type:	Light industrial ITE equipment	
Application of Council Directive:	89/336/EEC	
Standards:	EN 55022	
	EN 61000-6-1 EN 61000 (-4-2, -4-3, -4-4, -4-5, -4-6, -4-8, -4-11)	

Black Box Corporation - 1000 Park Drive - Lawrence, PA 15055-1018  
Tech Support and Ordering: 724-746-5500 - Fax: 724-746-0746  
To contact us about Black Box products or services: [info@blackbox.com](mailto:info@blackbox.com)



# MVC IV VOLTAGE CONTROL MANUAL

NEUNDORFER PRECIPITATOR KNOWLEDGE



## MED100A Fiber Optic Modem Data Sheet, page 4 of 4

Table 4: Operating Parameters

Parameter	Min.	Typical	Max.	Conditions
Data Rates (RS-232 Operation)	0 bps		115.2 kbps	
Data Rates (RS-422/485 Operation)	0 bps		500 kbps	
Power Supply Voltage	10 VDC	12 VDC	30 VDC	
Power Supply Current Draw			140 mA	Full RS-485 Termination
Optic Wavelength		820 nm		
Fiber TX Launch Power	-17 dBm	-13 dBm	-10 dBm	
Minimum Required Fiber Rx Power		-25.4 dBm	-24 dBm	
Maximum Receiver Power			-10 dBm	
Coupled Power Budget		12.1 dB		
Fiber Range		2.5 mi (4 km)		
End to End Delay		2000 ns	2650 ns	Point-to-Point RS-232 Operation (See Notes 1 & 2)
End to End Delay		550 ns	1000 ns	Point-to-Point RS-422/485 Operation (See Notes 1 & 2)
End to End Skew		900 ns	1100 ns	Point-to-Point RS-232 Operation (See Note 3)
End to End Skew		50 ns	120 ns	Point-to-Point RS-422/485 Operation (See Note 3)
Maximum Total Fiber Ring Length			5 mi (8 km)	(See Note 1)
Delay between Rx & Tx on a fiber ring	52 $\mu$ s			(See Note 4)

Note 1: For the total transmission time over long fibers, the time to transverse the fiber must be considered if delay is an issue. Light takes about 8.05 microseconds to travel over 1 mi (1.6 km) of fiber.  
 Note 2: When operating in a ring configuration, each node in addition to the two in the point-to-point specification adds an additional 100 to 200 nanoseconds of delay.  
 Note 3: When operating in a ring configuration, each node in addition to the two in the point-to-point specification adds an additional 50 to 70 nanoseconds of skew.  
 Note 4: When operating in a ring configuration, each serial device must wait at least this minimum time between receiving data from the ring and transmitting back on it.

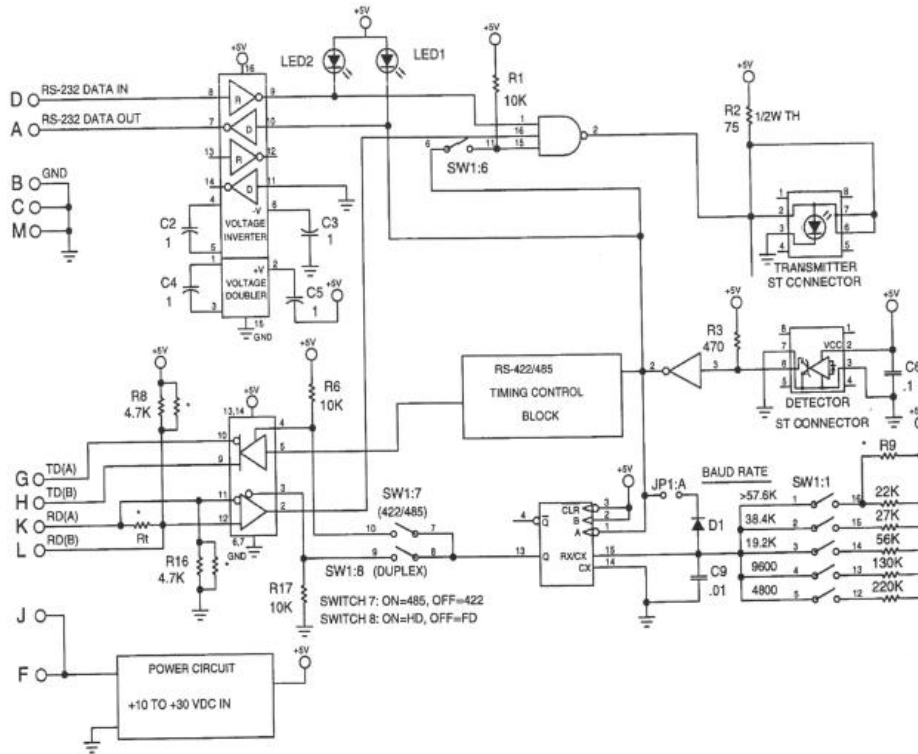

Figure 4: MED100A Circuit Diagram

Black Box Corporation - 1000 Park Drive - Lawrence, PA 15055-1018

Tech Support and Ordering: 724-746-5500 - Fax: 724-746-0746

To contact us about Black Box products or services: [info@blackbox.com](mailto:info@blackbox.com)





# MVC IV VOLTAGE CONTROL MANUAL

NEUNDORFER PRECIPITATOR KNOWLEDGE



This page intentionally blank.



# MVC IV VOLTAGE CONTROL MANUAL

NEUNDORFER PRECIPITATOR KNOWLEDGE



## C. STANDARD DRAWINGS

8-01-0222	Wiring Diagram, Data Link Network & POS, MVC4 Configuration
8-01-0223 (Sheets 1 & 2)	Schematic Diagram, Dual Bushing MVC4 (Generic)
8-01-0224	Connection Diagram, MVC4 Retrofit (Generic)
8-01-0225	Wiring Diagram, MVC4 Cabinet (Generic)
8-01-0229	Interface Board Connections, MVC4 (Generic)
8-01-0230	Logic Board Connections, MVC4 (Generic)
8-01-0226	Cabinet Layout, MVC4 Standard
8-01-0232 (Sheets 1 & 2)	Outline & Drill Template, MVC4 Display
82200-104	Outline, KV Signal Feedback Surge Suppression PCB